

ESP32-C5 Series

Datasheet Version 1.3

Ultra-low-power SoC with 32-bit RISC-V single-core microprocessor
2.4 and 5 GHz dual-band Wi-Fi 6 (802.11ax), Bluetooth® 5 (LE), Zigbee, and
Thread (802.15.4)

Support connection to external flash and PSRAM

29 GPIOs, rich set of peripherals

QFN48 (6×6 mm) package

Including:

ESP32-C5HR2

ESP32-C5HR8

ESP32-C5HF4



ESPRESSIF

Product Overview

The ESP32-C5 SoC (System on Chip) supports 2.4 and 5 GHz dual-band Wi-Fi 6, Bluetooth LE 5, Zigbee 3.0 and Thread 1.4. It consists of a high-performance (HP) 32-bit RISC-V processor, an low-power (LP) 32-bit RISC-V processor, wireless baseband and MAC (Wi-Fi, Bluetooth LE, and 802.15.4), RF module, and numerous peripherals, with time-division coexistence of Wi-Fi, Bluetooth and 802.15.4.

The functional block diagram of the SoC is shown below.

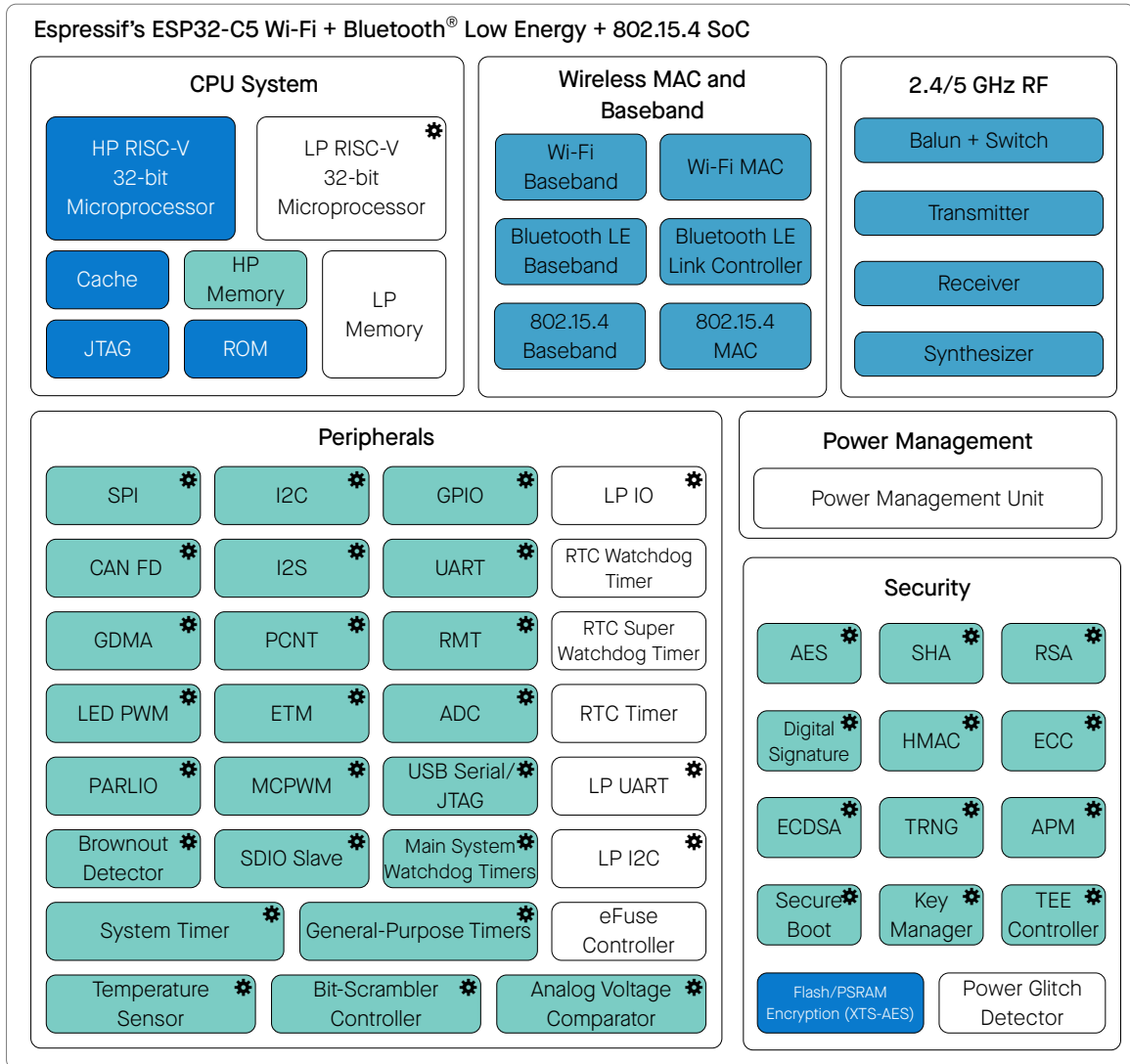

Modules having power in specific power modes:

- Active
- Active and Modem-sleep
- Active, Modem-sleep, Light-sleep; optional in Light-sleep *
- All modes
- optional in Deep-sleep *

ESP32-C5 Functional Block Diagram

For more information on power consumption, see Section [4.1.3.6 Power Management Unit](#).

Features

Wi-Fi

- 1T1R in 2.4 and 5 GHz dual band
- Operating frequency: 2412 ~ 2484 MHz, 5180 ~ 5885 MHz
- Data rate up to 150 Mbps
- IEEE 802.11ax-compliant
 - 20 MHz-only non-AP mode
 - Uplink and downlink OFDMA to enhance connectivity and performance in congested environments for IoT applications
 - Downlink MU-MIMO (multi-user, multiple input, multiple output) to increase network capacity
 - Beamformee that improves signal quality
 - Spatial reuse to maximize parallel transmissions
 - Target wake time (TWT) that optimizes power saving mechanisms
- IEEE 802.11ac-compliant
 - 20 MHz bandwidth
 - Downlink fullband MU-MIMO
- Fully compatible with IEEE 802.11a/b/g/n protocol
 - 20 MHz and 40 MHz bandwidth
 - MCS0 ~ MCS7
 - Wi-Fi multimedia (WMM)
 - TX/RX A-MPDU, TX/RX A-MSDU
 - Immediate block ACK
 - Fragmentation and defragmentation
 - Transmission opportunity (TXOP)
 - Automatic beacon monitoring (hardware TSF)
 - Four virtual Wi-Fi interfaces
 - Simultaneous support for Infrastructure BSS in Station mode, SoftAP mode, Station + SoftAP mode, and promiscuous mode
 - Note that when ESP32-C5 scans in Station mode, the SoftAP channel will change along with the Station channel*
 - Antenna diversity
 - 802.11mc FTM

Bluetooth®

- Bluetooth LE: Bluetooth Core 6.0 certified
- Bluetooth mesh 1.1
- High power mode with up to 20 dBm transmission power
- Direction finding (AoA/AoD)
- Periodic advertising with responses (PAWR)
- LE connection subrating
- LE power control
- Speed: 125 Kbps, 500 Kbps, 1 Mbps, 2 Mbps
- LE advertising extensions and multiple advertising sets
- Allow devices to operate in Broadcaster, Observer, Central, and Peripheral roles concurrently

IEEE 802.15.4

- Compliant with IEEE 802.15.4-2015 protocol
- OQPSK PHY in 2.4 GHz band
- Data rate: 250 Kbps
- Thread 1.4
- Zigbee 3.0

CPU and Memory

- High-performance (HP) RISC-V processor:
 - Clock speed: up to 240 MHz
 - Five-stage pipeline
 - CoreMark® score: 820.19 CoreMark; 3.42 CoreMark/MHz (O3)
- Low-power (LP) RISC-V processor:
 - Clock speed: up to 48 MHz
 - Two-stage pipeline
- ROM: 320 KB
- HP SRAM: 384 KB
- LP SRAM: 16 KB
- Flash/PSRAM controller with cache is supported
- Flash in-circuit programming (ICP) is supported

Advanced Peripheral Interfaces

- 29 programmable GPIOs
- Analog signal processing:
 - 12-bit SAR ADC, up to 6 channels
 - Temperature sensor
 - Brownout detector
 - Analog voltage comparator
- Digital interfaces:
 - Two UART controllers
 - Low-power (LP) UART controller
 - Two SPI ports for communication with flash/PSRAM
 - General-purpose SPI port
 - I2C
 - Low-power (LP) I2C
 - I2S
 - Pulse count controller
 - USB Serial/JTAG controller
 - Two CAN FD controllers, compatible with ISO 11898-1:2015
 - SDIO slave controller (not supported by chip revision v0.0 and v0.1)
 - LED PWM controller, up to 6 channels
 - Motor control PWM (MCPWM), up to 6 channels
 - Remote control peripheral (RMT) (TX/RX)
 - Parallel IO interface (PARLIO)
 - General DMA controller (GDMA), with 3 transmit channels and 3 receive channels
 - BitScrambler
 - Event task matrix (ETM)
- Timers:
 - 52-bit system timer
 - Two 54-bit general-purpose timers
 - 48-bit RTC timer
 - Three digital watchdog timers
 - Analog watchdog timer

Security

- Cryptographic hardware acceleration:
 - AES-128/256 (NIST FIPS 197)
 - SHA
 - RSA
 - ECC
 - HMAC
 - RSA Digital Signature Peripheral (RSA_DS)
 - ECDSA (Elliptic Curve Digital Signature Algorithm) Digital Signature Peripheral (ECDSA_DS)
- External memory encryption and decryption (XTS_AES)
- Secure boot
- True random number generator (TRNG)
- Key manager (supported by chip revision v1.2 or later)
- Access permission management (APM) and trusted execution environment (TEE) controller
- Power glitch detector

RF Module

- Antenna switches, RF balun, power amplifier, low-noise receive amplifier
- Up to +20 dBm of power for an 802.11b transmission
- Up to +19 dBm of power for an 802.11ax transmission
- Up to -107 dBm of sensitivity for Bluetooth LE receiver (125 Kbps)

Applications

With low power consumption, ESP32-C5 is an ideal choice for IoT devices in the following areas:

- Smart Home
- Industrial Automation
- Health Care
- Consumer Electronics
- Smart Agriculture
- POS Machines
- Service Robot
- Audio Devices
- Generic Low-power IoT Sensor Hubs
- Generic Low-power IoT Data Loggers
- Wi-Fi + Bluetooth Networking Card

Note:

Check the link or the QR code to make sure that you use the latest version of this document:
https://www.espressif.com/documentation/esp32-c5_datasheet_en.pdf



Contents

Product Overview	2
Features	3
Applications	6
1 ESP32-C5 Series Information	14
1.1 Nomenclature	14
1.2 Comparison	14
1.3 Chip Revision	14
2 Pins	16
2.1 Pin Layout	16
2.2 Pin Overview	18
2.3 IO Pins	21
2.3.1 HP IO MUX Functions	21
2.3.2 LP IO MUX Functions	23
2.3.3 Analog Functions	24
2.3.4 Restrictions for GPIOs and LP GPIOs	25
2.3.5 Peripheral Pin Assignment	26
2.4 Analog Pins	28
2.5 Power Supply	29
2.5.1 Power Pins	29
2.5.2 Power Scheme	29
2.5.3 Chip Power-up and Reset	30
2.6 Pin Mapping Between Chip and Flash/PSRAM	31
3 Boot Configurations	32
3.1 Chip Boot Mode Control	34
3.2 SDIO Sampling and Driving Clock Edge Control	34
3.3 ROM Messages Printing Control	35
3.4 JTAG Signal Source Control	35
4 Functional Description	37
4.1 System	37
4.1.1 Microprocessor and Master	37
4.1.1.1 High-Performance CPU	37
4.1.1.2 RISC-V Trace Encoder	37

4.1.1.3	Low-Power CPU	38
4.1.1.4	GDMA Controller	38
4.1.2	Memory Organization	39
4.1.2.1	Internal Memory	40
4.1.2.2	External Memory	40
4.1.2.3	eFuse Controller	40
4.1.2.4	cache	41
4.1.3	System Components	41
4.1.3.1	IO MUX and GPIO Matrix	41
4.1.3.2	Reset	42
4.1.3.3	Clock	42
4.1.3.4	Interrupt Matrix	43
4.1.3.5	Event Task Matrix	43
4.1.3.6	Power Management Unit	43
4.1.3.7	System Timer	44
4.1.3.8	Timer Group	44
4.1.3.9	Watchdog Timers	45
4.1.3.10	RTC Timer	46
4.1.3.11	Permission Control	46
4.1.3.12	System Registers	46
4.1.3.13	Debug Assistant	46
4.1.3.14	Brownout Detector	47
4.1.4	Cryptography and Security Component	47
4.1.4.1	AES Accelerator	47
4.1.4.2	ECC Accelerator	48
4.1.4.3	HMAC Accelerator	48
4.1.4.4	RSA Accelerator	49
4.1.4.5	SHA Accelerator	49
4.1.4.6	RSA Digital Signature Peripheral (RSA_DS)	50
4.1.4.7	ECDSA Digital Signature Peripheral (ECDSA_DS)	50
4.1.4.8	External Memory Encryption and Decryption	51
4.1.4.9	True Random Number Generator	51
4.1.4.10	Key Manager	51
4.1.4.11	Power Glitch Detector	53
4.2	Peripherals	54
4.2.1	Connectivity Interface	54
4.2.1.1	UART Controller	54
4.2.1.2	SPI Controller	54
4.2.1.3	I2C Controller	55
4.2.1.4	I2S Controller	55
4.2.1.5	USB Serial/JTAG Controller	57
4.2.1.6	CAN FD Controller	57
4.2.1.7	LED PWM Controller	58
4.2.1.8	Pulse Count Controller	58
4.2.1.9	Motor Control PWM	59
4.2.1.10	Remote Control Peripheral	59

4.2.1.11	Parallel IO Controller	60
4.2.1.12	BitScrambler	60
4.2.1.13	SDIO Slave Controller	61
4.2.2	Analog Signal Processing	62
4.2.2.1	Temperature Sensor	62
4.2.2.2	ADC Controller	62
4.2.2.3	Analog Voltage Comparator	63
4.3	Wireless Communication	64
4.3.1	Radio	64
4.3.1.1	2.4 & 5 GHz Receiver	64
4.3.1.2	2.4 & 5 GHz Transmitter	64
4.3.1.3	Clock Generator	64
4.3.2	Wi-Fi	64
4.3.2.1	Wi-Fi Radio and Baseband	65
4.3.2.2	Wi-Fi MAC	66
4.3.2.3	Networking Features	66
4.3.3	Bluetooth LE	67
4.3.3.1	Bluetooth LE PHY	67
4.3.3.2	Bluetooth LE Link Controller	67
4.3.4	802.15.4	68
4.3.4.1	802.15.4 PHY	68
4.3.4.2	802.15.4 MAC	68
5	Electrical Characteristics	69
5.1	Absolute Maximum Ratings	69
5.2	Recommended Power Supply Characteristics	69
5.3	VDD_SPI Output Characteristics	70
5.4	DC Characteristics (3.3 V, 25 °C)	70
5.5	ADC Characteristics	70
5.6	Current Consumption	71
5.6.1	RF Current Consumption in Active Mode	71
5.6.2	Current Consumption in Other Modes	73
5.7	Memory Specifications	73
5.8	Reliability	74
6	RF Characteristics	76
6.1	2.4 GHz Wi-Fi Radio	76
6.1.1	2.4 GHz Wi-Fi RF Transmitter (TX) Characteristics	76
6.1.2	2.4 GHz Wi-Fi RF Receiver (RX) Characteristics	77
6.2	5 GHz Wi-Fi Radio	79
6.2.1	5 GHz Wi-Fi RF Transmitter (TX) Characteristics	79
6.2.2	5 GHz Wi-Fi RF Receiver (RX) Characteristics	80
6.3	Bluetooth LE Radio	82
6.3.1	Bluetooth LE RF Transmitter (TX) Characteristics	82
6.3.2	Bluetooth LE RF Receiver (RX) Characteristics	83
6.4	802.15.4 Radio	85

6.4.1	802.15.4 RF Transmitter (TX) Characteristics	86
6.4.2	802.15.4 RF Receiver (RX) Characteristics	86
7	Packaging	87
	ESP32-C5 Consolidated Pin Overview	88
	Datasheet Versioning	89
	Glossary	90
	Related Documentation and Resources	91
	Revision History	93

List of Tables

1-1	ESP32-C5 Series Information	14
2-1	Pin Overview	18
2-2	Peripheral Signals Routed via HP IO MUX	21
2-3	IO MUX Pin Functions	22
2-4	LP Peripheral Signals Routed via LP IO MUX	23
2-5	LP IO MUX Functions	23
2-6	Analog Signals Routed to Analog Functions	24
2-7	Analog Functions	24
2-8	Peripheral Pin Assignment	27
2-9	Analog Pins	28
2-10	Power Pins	29
2-11	Voltage Regulators	29
2-12	Description of Timing Parameters for Power-up and Reset	30
2-13	Pin Mapping Between Chip and Off-Package Flash	31
2-14	Pin Mapping Between Chip and Off-Package PSRAM	31
3-1	Default Configuration of Strapping Pins	32
3-2	Description of Timing Parameters for the Strapping Pins	33
3-3	Chip Boot Mode Control	34
3-4	SDIO Input Sampling Edge/Output Driving Edge Control	34
3-5	UART0 ROM Message Printing Control	35
3-6	USB Serial/JTAG ROM Message Printing Control	35
3-7	JTAG Signal Source Control	36
5-1	Absolute Maximum Ratings	69
5-2	Recommended Power Characteristics	69
5-3	VDD_SPI Internal and Output Characteristics	70
5-4	DC Characteristics (3.3 V, 25 °C)	70
5-5	ADC Characteristics	71
5-6	ADC Calibration Results	71
5-7	Current Consumption for Wi-Fi (2.4 GHz) in Active Mode	71
5-8	Current Consumption for Wi-Fi (5 GHz) in Active Mode	72
5-9	Current Consumption for Bluetooth LE in Active Mode	72
5-10	Current Consumption for 802.15.4 in Active Mode	72
5-11	Current Consumption in Modem-sleep Mode	73
5-12	Current Consumption in Low-Power Modes	73
5-13	Flash Specifications	73
5-14	PSRAM Specifications	74
5-15	Reliability Qualifications	74
6-1	2.4 GHz Wi-Fi RF Characteristics	76
6-2	2.4 GHz TX Power with Spectral Mask and EVM Meeting 802.11 Standards	76
6-3	2.4 GHz TX EVM Test ¹	76
6-4	2.4 GHz RX Sensitivity	77
6-5	2.4 GHz Maximum RX Level	78
6-6	2.4 GHz RX Adjacent Channel Rejection	78

6-7	5 GHz Wi-Fi RF Characteristics	79
6-8	5 GHz TX Power with Spectral Mask and EVM Meeting 802.11 Standards	79
6-9	5 GHz TX EVM Test ¹	79
6-10	5 GHz RX Sensitivity	80
6-11	5 GHz Maximum RX Level	81
6-12	5 GHz RX Adjacent Channel Rejection	81
6-13	Bluetooth LE RF Characteristics	82
6-14	Bluetooth LE - Transmitter Characteristics - 1 Mbps	82
6-15	Bluetooth LE - Transmitter Characteristics - 2 Mbps	82
6-16	Bluetooth LE - Transmitter Characteristics - 125 Kbps	83
6-17	Bluetooth LE - Transmitter Characteristics - 500 Kbps	83
6-18	Bluetooth LE - Receiver Characteristics - 1 Mbps	83
6-19	Bluetooth LE - Receiver Characteristics - 2 Mbps	84
6-20	Bluetooth LE - Receiver Characteristics - 125 Kbps	85
6-21	Bluetooth LE - Receiver Characteristics - 500 Kbps	85
6-22	802.15.4 RF Characteristics	85
6-23	802.15.4 Transmitter Characteristics - 250 Kbps	86
6-24	802.15.4 Receiver Characteristics - 250 Kbps	86
7-1	Pin Overview	88

List of Figures

1-1	ESP32-C5 Series Nomenclature	14
2-1	ESP32-C5HR2 & ESP32-C5HR8 Pin Layout (Top View)	16
2-2	ESP32-C5HF4 Pin Layout (Top View)	17
2-3	ESP32-C5 Power Scheme	30
2-4	Visualization of Timing Parameters for Power-up and Reset	30
3-1	Visualization of Timing Parameters for the Strapping Pins	33
4-1	Address Mapping Structure	39
7-1	QFN48 (6 × 6 mm) Package	87

1 ESP32-C5 Series Information

1.1 Nomenclature

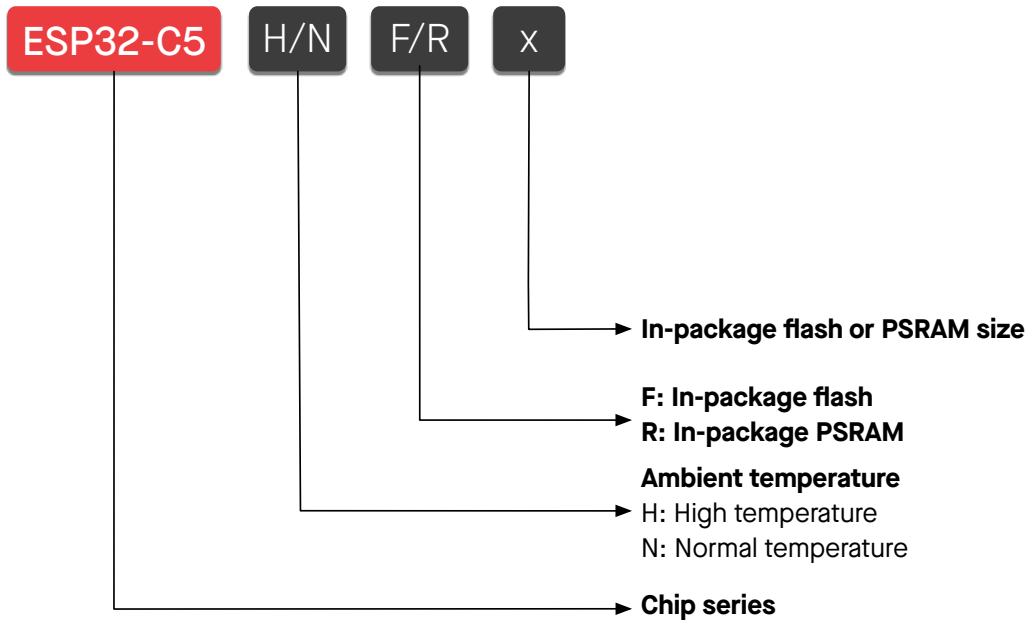

Figure 1-1. ESP32-C5 Series Nomenclature

1.2 Comparison

Table 1-1. ESP32-C5 Series Information

Part Number ¹	Ambient Temp. ² (°C)	In-package flash ³	In-Package PSRAM	Package	Chip Revision
ESP32-C5HR2 ⁴	-40 ~ 105	—	2 MB (Quad SPI) ⁵	QFN48 (6×6 mm)	v1.2
ESP32-C5HR8			8 MB (Quad SPI)		v1.0/v1.2
ESP32-C5HF4		4 MB (Quad SPI)	—		

¹ For details on chip marking and packing, see Section 7 *Packaging*.

² Ambient temperature specifies the recommended temperature range of the environment outside an Espressif chip.

³ For information about *in-package flash*, see also Section 4.1.2.1 *Internal Memory*. By default, the SPI flash on the chip operates at a maximum clock frequency of 80 MHz and does not support the auto suspend feature. If you have a requirement for a higher flash clock frequency of 120 MHz or if you need the flash auto suspend feature, please [contact us](#).

⁴ The variant is not yet in mass production.

⁵ For details about SPI modes, see Section 2.6 *Pin Mapping Between Chip and Flash/PSRAM*.

1.3 Chip Revision

As shown in Table 1-1 *ESP32-C5 Series Information*, ESP32-C5 now has multiple chip revisions available on the market using the same part number.

For chip revision identification, ESP-IDF release that supports a specific chip revision, and errors fixed in each chip revision, please refer to [ESP32-C5 Series SoC Errata](#).

2 Pins

2.1 Pin Layout

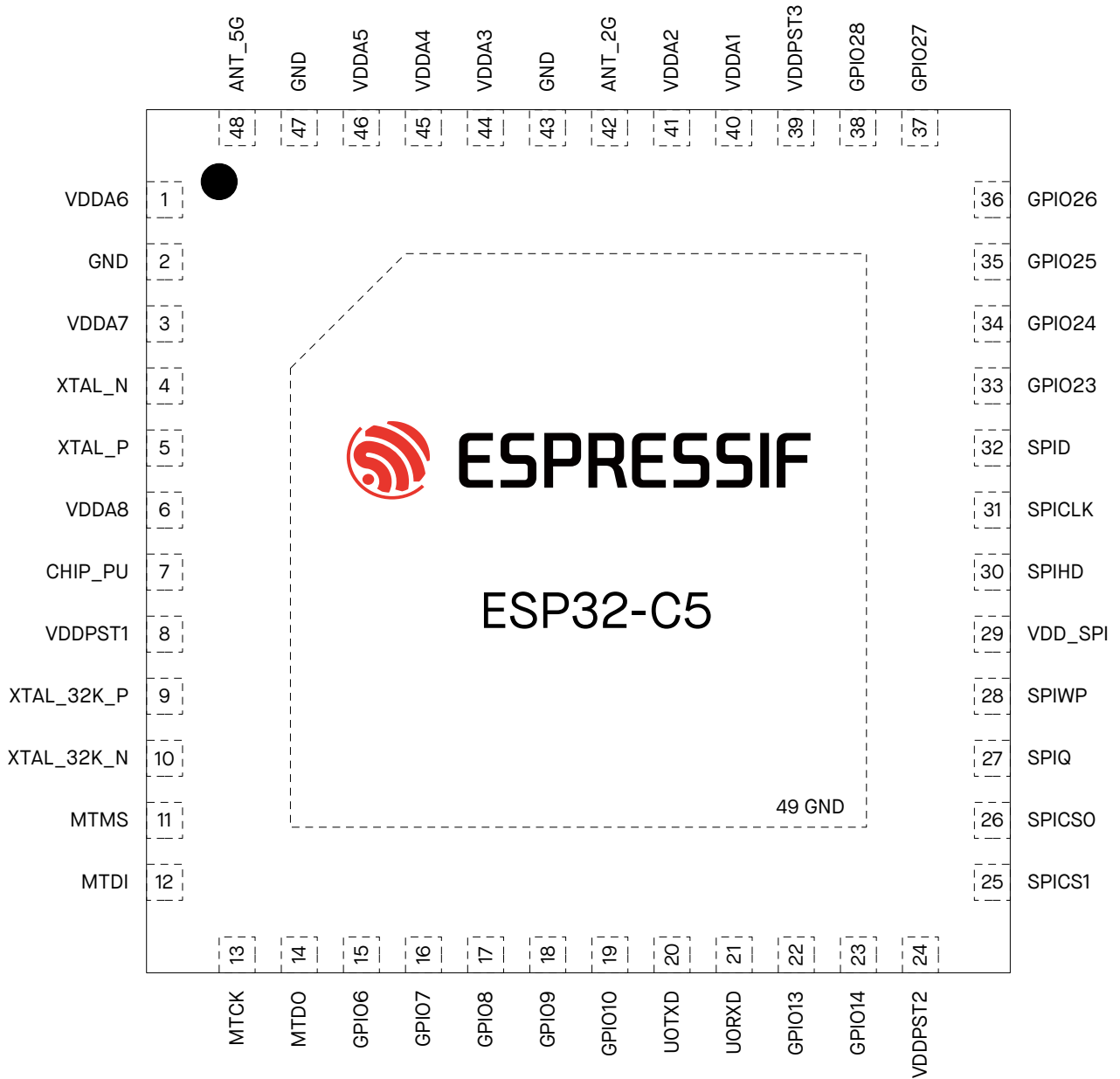

Figure 2-1. ESP32-C5HR2 & ESP32-C5HR8 Pin Layout (Top View)

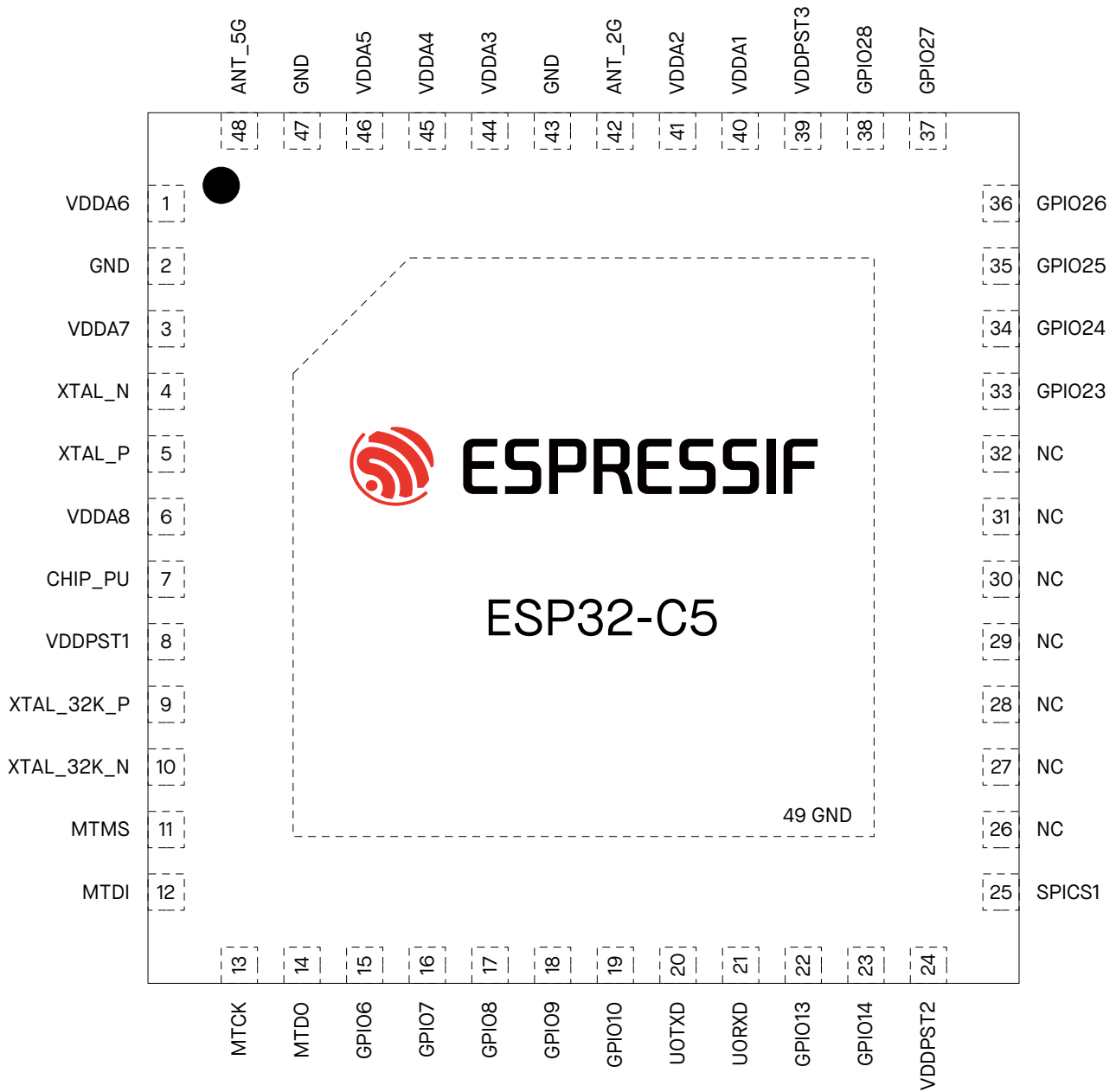

Figure 2-2. ESP32-C5HF4 Pin Layout (Top View)

2.2 Pin Overview

The ESP32-C5 chip integrates multiple peripherals that require communication with the outside world. To keep the chip package size reasonably small, the number of available pins has to be limited. So the only way to route all the incoming and outgoing signals is through pin multiplexing. Pin muxing is controlled via software programmable registers. For details, see [ESP32-C5 Technical Reference Manual](#) > Chapter *IO MUX and GPIO Matrix*.

All in all, the ESP32-C5 chip has the following types of pins:

- **IO pins** with the following predefined sets of functions to choose from:
 - Each IO pin has predefined **HP IO MUX functions** – see Table [2-3 IO MUX Pin Functions](#)
 - Some IO pins have predefined **LP IO MUX functions** – see Table [2-5 LP IO MUX Functions](#)
 - Some IO pins have predefined **analog functions** – see Table [2-7 Analog Functions](#)

Predefined functions means that each IO pin has a set of direct connections to certain signals from on-chip peripherals. During run-time, the user can configure which peripheral signal from a predefined set to connect to a certain pin at a certain time via memory mapped registers.

- **Analog pins** that have exclusively-dedicated **analog functions** – see Table [2-9 Analog Pins](#)
- **Power pins** supply power to the chip components and non-power pins – see Table [2-10 Power Pins](#)

Table [2-1 Pin Overview](#) gives an overview of all the pins. For more information, see respective sections below. Alternatively, see [Appendix A – ESP32-C5 Consolidated Pin Overview](#).

Table 2-1. Pin Overview

Pin No.	Pin Name	Pin Type	Pin Providing Power ²⁻⁴	Pin Settings ^{4,5}		Pin Function Sets ¹		
				At Reset	After Reset	HP IO MUX	LP IO MUX	Analog
1	VDDA6	Power						
2	GND	Power						
3	VDDA7	Power						
4	XTAL_N	Analog						
5	XTAL_P	Analog						
6	VDDA8	Power						
7	CHIP_PU	Analog	VDDPST1					
8	VDDPST1	Power						
9	XTAL_32K_P	IO	VDDPST1			HP IO MUX	LP IO MUX	Analog
10	XTAL_32K_N	IO	VDDPST1			HP IO MUX	LP IO MUX	Analog
11	MTMS	IO	VDDPST1	IE	IE	HP IO MUX	LP IO MUX	Analog
12	MTDI	IO	VDDPST1	IE	IE	HP IO MUX	LP IO MUX	Analog
13	MTCK	IO	VDDPST1		IE, WPU	HP IO MUX	LP IO MUX	Analog
14	MTDO	IO	VDDPST1	IE	IE	HP IO MUX	LP IO MUX	Analog
15	GPIO6	IO	VDDPST1	IE	IE	HP IO MUX	LP IO MUX	Analog
16	GPIO7	IO	VDDPST1	IE	IE	HP IO MUX		
17	GPIO8	IO	VDDPST1		IE	HP IO MUX		Analog
18	GPIO9	IO	VDDPST1		IE	HP IO MUX		Analog
19	GPIO10	IO	VDDPST1		IE	HP IO MUX		

Cont'd on next page

Table 2-1 – cont'd from previous page

Pin No.	Pin Name	Pin Type	Pin Providing Power ²⁻⁴	Pin Settings ^{4,5}		Pin Function Sets ¹		
				At Reset	After Reset	HP IO MUX	LP IO MUX	Analog
20	U0TXD	IO	VDDPST1		IE, OE	HP IO MUX		
21	U0RXD	IO	VDDPST1		IE, WPU	HP IO MUX		
22	GPIO13	IO	VDDPST2		IE	HP IO MUX		Analog
23	GPIO14	IO	VDDPST2	USB_PU	IE, USB_PU ⁴	HP IO MUX		Analog
24	VDDPST2	Power						
25	SPICS1	IO	VDD_SPI	WPU	IE, WPU	HP IO MUX		
26	SPICS0/NC ⁶	IO	VDD_SPI	WPU	IE, WPU	HP IO MUX		
27	SPIQ/NC ⁶	IO	VDD_SPI	WPU	IE, WPU	HP IO MUX		
28	SPIWP/NC ⁶	IO	VDD_SPI	WPU	IE, WPU	HP IO MUX		
29	VDD_SPI/NC ⁶	Power/IO	—			HP IO MUX		Analog
30	SPIHD/NC ⁶	IO	VDD_SPI	WPU	IE, WPU	HP IO MUX		
31	SPICLK/NC ⁶	IO	VDD_SPI	WPU	IE, WPU	HP IO MUX		
32	SPID/NC ⁶	IO	VDD_SPI	WPU	IE, WPU	HP IO MUX		
33	GPIO23	IO	VDDPST3		IE	HP IO MUX		
34	GPIO24	IO	VDDPST3		IE	HP IO MUX		
35	GPIO25	IO	VDDPST3	IE	IE	HP IO MUX		
36	GPIO26	IO	VDDPST3	IE	IE	HP IO MUX		
37	GPIO27	IO	VDDPST3	IE, WPU	IE, WPU	HP IO MUX		
38	GPIO28	IO	VDDPST3	IE, WPU	IE, WPU ⁵	HP IO MUX		
39	VDDPST3	Power						
40	VDDA1	Power						
41	VDDA2	Power						
42	ANT_2G	Analog						
43	GND	Power						
44	VDDA3	Power						
45	VDDA4	Power						
46	VDDA5	Power						
47	GND	Power						
48	ANT_5G	Analog						

1. **Bold** marks the pin function set in which a pin has its default function in the default boot mode. See Section 3.1 *Chip Boot Mode Control*.
2. In column **Pin Providing Power**, regarding pins powered by VDD_SPI:
 - Power actually comes from the internal power rail supplying power to VDD_SPI. For details, see Section 2.5.2 *Power Scheme*.
3. Except for GPIO13 and GPIO14 whose default drive strength is 40 mA, the default drive strength for all the other pins is 20 mA.
4. Column **Pin Settings** shows predefined settings at reset and after reset with the following abbreviations:
 - IE – input enabled
 - OE – output enabled
 - WPU – internal weak pull-up resistor enabled
 - WPD – internal weak pull-down resistor enabled
 - USB_PU – USB pull-up resistor enabled
 - By default, the USB function is enabled for USB pins (i.e., GPIO13 and GPIO14), and the pin pull-up is decided by the USB pull-up. The USB pull-up resistor is controlled by USB_SERIAL_JTAG_DP/DM_PULLUP and its pull-up value is controlled by USB_SERIAL_JTAG_PULLUP_VALUE. For details, see [ESP32-C5 Technical Reference Manual](#) > Chapter *USB Serial/JTAG Controller*.

- When the USB function is disabled, USB pins are used as regular GPIOs. In this case, the internal weak pull-up and pull-down resistors of the USB pins are disabled by default, but are configurable by IO_MUX_GPIO_FUN_WPU/WPD. For details, see [ESP32-C5 Technical Reference Manual](#) > Chapter *IO MUX and GPIO Matrix (GPIO, IO MUX)*.
5. Depends on the value of EFUSE_DIS_PAD_JTAG
 - 0 - default value. Input enabled, and internal weak pull-up resistor enabled (IE & WPU)
 - 1 - input enabled (IE)
 6. For ESP32-C5HF4, the SPICSO, SPIQ, SPIWP, VDD_SPI, SPIHD, SPICLK, and SPID pins are not connected (NC).

2.3 IO Pins

For details on configuring IO pins, see [ESP32-C5 Technical Reference Manual](#) > Chapter *IO MUX and GPIO Matrix (GPIO, IO MUX)*.

2.3.1 HP IO MUX Functions

The HP IO MUX multiplexes HP-domain peripheral signals onto IO pins, allowing multiple input/output signals to be connected to a single input/output pin. Each IO pin of ESP32-C5 can be connected to one of the three signals (IO MUX functions, i.e., FO-F2), as listed in Table 2-3 *IO MUX Pin Functions*.

Among the three sets of signals:

- Some are routed via the GPIO Matrix (**GPIO0, GPIO1, etc.**), which incorporates internal signal routing circuitry for mapping signals programmatically. It gives the pin access to almost any peripheral signals. However, the flexibility of programmatic mapping comes at a cost as it might affect the latency of routed signals. For details about connecting to peripheral signals via GPIO Matrix, see [ESP32-C5 Technical Reference Manual](#) > Chapter *IO MUX and GPIO Matrix*.
- Some are directly routed from certain peripherals (**UOTXD, MTCK, etc.**), including UART0, JTAG, SPI0/1, and SPI2 - see Table 2-2 *Peripheral Signals Routed via HP IO MUX*.

Table 2-2. Peripheral Signals Routed via HP IO MUX

Pin Function	Signal	Description
UOTXD UORXD	Transmit data Receive data	UART0 interface
MTCK MTDO MTDI MTMS	Test clock Test Data Out Test Data In Test Mode Select	JTAG interface for debugging
SPIQ SPID SPIHD SPIWP SPICLK SPICS...	Master in, slave out Master out, slave in Hold Write protect Clock Chip select	SPI0/1 interface for connection to <i>off-package flash</i> via the SPI bus. See also Section 2.6 <i>Pin Mapping Between Chip and Flash/PSRAM</i>
FSPIQ FSPID FSPIHD FSPIWP FSPICLK FSPICS0	Master in, slave out Master out, slave in Hold Write protect Clock Chip select	SPI2 main interface for fast SPI connection. Among these pins, FSPICS0 is for input or output signals in master or slave mode
SDIO_CLK SDIO_CMD SDIO_DATA...	Clock Command Data	SDIO interface for connection to external SDIO hosts

Table 2-3 *IO MUX Pin Functions* shows the HP IO MUX functions of IO pins.

Table 2-3. IO MUX Pin Functions

Pin No.	IO MUX/ GPIO Name ^{1, 2}	IO MUX Function ^{1, 2}					
		0	Type ³	1	Type	2	Type
9	GPIO0	GPIO0	I/O/T	GPIO0	I/O/T		
10	GPIO1	GPIO1	I/O/T	GPIO1	I/O/T		
11	GPIO2	MTMS	I1	GPIO2	I/O/T	FSPIQ	I1/O/T
12	GPIO3	MTDI	I1	GPIO3	I/O/T		I1/O/T
13	GPIO4	MTCK	I1	GPIO4	I/O/T	FSPIHD	I1/O/T
14	GPIO5	MTDO	O/T	GPIO5	I/O/T	FSPIWP	I1/O/T
15	GPIO6	GPIO6	I/O/T	GPIO6	I/O/T	FSPICLK	I1/O/T
16	GPIO7	SDIO_DATA1	I1/O/T	GPIO7	I/O/T	FSPID	I1/O/T
17	GPIO8	SDIO_DATA0	I1/O/T	GPIO8	I/O/T		
18	GPIO9	SDIO_CLK	I1	GPIO9	I/O/T		
19	GPIO10	SDIO_CMD	I1/O/T	GPIO10	I/O/T	FSPICSO	I1/O/T
20	GPIO11	UOTXD	O	GPIO11	I/O/T		
21	GPIO12	UORXD	I1	GPIO12	I/O/T		
22	GPIO13	SDIO_DATA3	I1/O/T	GPIO13	I/O/T		
23	GPIO14	SDIO_DATA2	I1/O/T	GPIO14	I/O/T		
25	GPIO15	SPICS1	O/T	GPIO15	I/O/T		
26	GPIO16	SPICSO	O/T	GPIO16	I/O/T		
27	GPIO17	SPIQ	I1/O/T	GPIO17	I/O/T		
28	GPIO18	SPIWP	I1/O/T	GPIO18	I/O/T		
29	GPIO19	GPIO19	I/O/T	GPIO19	I/O/T		
30	GPIO20	SPIHD	I1/O/T	GPIO20	I/O/T		
31	GPIO21	SPICLK	O/T	GPIO21	I/O/T		
32	GPIO22	SPID	I1/O/T	GPIO22	I/O/T		
33	GPIO23	GPIO23	I/O/T	GPIO23	I/O/T		
34	GPIO24	GPIO24	I/O/T	GPIO24	I/O/T		
35	GPIO25	GPIO25	I/O/T	GPIO25	I/O/T		
36	GPIO26	GPIO26	I/O/T	GPIO26	I/O/T		
37	GPIO27	GPIO27	I/O/T	GPIO27	I/O/T		
38	GPIO28	GPIO28	I/O/T	GPIO28	I/O/T		

¹ **Bold** marks the default pin functions in the default boot mode. For more information about the default boot mode, see Section 3.1 *Chip Boot Mode Control*.

² Regarding **highlighted** cells, see Section 2.3.4 *Restrictions for GPIOs and LP GPIOs*.

³ Each HP IO MUX function (F_n , $n = 0 \sim 2$) is associated with a *type*. The description of *type* is as follows:

- I – input. O – output. T – high impedance.
- I1 – input; if the pin is assigned a function other than F_n , the input signal of F_n is always 1.
- IO – input; if the pin is assigned a function other than F_n , the input signal of F_n is always 0.

2.3.2 LP IO MUX Functions

When the chip is in Deep-sleep mode, the HP IO MUX functions described in Section 2.3.1 *HP IO MUX Functions* will not work. That is where the LP IO MUX comes in. It allows multiple input/output signals to be a single input/output pin in Deep-sleep mode, as the pin is connected to the LP system and powered by VDDPST1.

LP IO pins can be assigned to **LP functions**. They can

- Either work as LP GPIOs (**LP_GPIO0, LP_GPIO1, etc.**), connected to the LP CPU
- Or connect to LP peripheral signals (**LP_I2C_SDA, LP_I2C_SCL, etc.**) - see Table 2-4 *LP Peripheral Signals Routed via LP IO MUX*

Table 2-4. LP Peripheral Signals Routed via LP IO MUX

Pin Function	Signal	Description
LP_I2C_SDA	Serial data	LP I2C interface
LP_I2C_SCL	Serial clock	
LP_UART_RXD	Receive	LP UART interface
LP_UART_TXD	Transmit	
LP_UART_RTSN	Request to send	
LP_UART_CTSN	Clear to send	
LP_UART_DTRN	Data set ready	
LP_UART_DSRN	Data terminal ready	

Table 2-5 *LP IO MUX Functions* shows the LP functions of LP IO pins.

Table 2-5. LP IO MUX Functions

Pin No.	LP IO Name ¹	LP IO MUX Function			
		F0	F1	F2	F3
9	LP_GPIO0	LP_UART_DTRN	LP_GPIO0		
10	LP_GPIO1	LP_UART_DSRN	LP_GPIO1		
11	LP_GPIO2	LP_UART_RTSN ²	LP_GPIO2		LP_I2C_SDA ²
12	LP_GPIO3	LP_UART_CTSN	LP_GPIO3		LP_I2C_SCL
13	LP_GPIO4	LP_UART_RXD	LP_GPIO4		
14	LP_GPIO5	LP_UART_TXD	LP_GPIO5		
15	LP_GPIO6		LP_GPIO6		

¹ This column lists the LP GPIO names, since LP functions are configured with LP GPIO registers that use LP GPIO numbering.

² Hardware flow control of LP_UART cannot be used with LP_I2C at the same time.

2.3.3 Analog Functions

Some IO pins also have **analog functions**, for analog peripherals (such as ADC) in any power mode. Internal analog signals are routed to these analog functions, see Table 2-6 *Analog Signals Routed to Analog Functions*.

Table 2-6. Analog Signals Routed to Analog Functions

Pin Function	Signal	Description
ADC1_CH...	ADC1 channel ... signal	ADC1 interface
XTAL_32K_N	Negative clock signal	32 kHz external clock input/output connected to ESP32-C5's crystal or oscillator
XTAL_32K_P	Positive clock signal	
USB_D-	Data -	USB Serial/JTAG function
USB_D+	Data +	
PAD_COMP...	PAD... signal	Analog voltage comparator input

Table 2-7 *Analog Functions* shows the analog functions of IO pins.

Table 2-7. Analog Functions

QFN48 Pin No.	Analog IO Name ¹	Analog Function ^{2, 3}	
		FO	F1
9	GPIO0	XTAL_32K_P	
10	GPIO1	XTAL_32K_N	ADC1_CH0
11	GPIO2		ADC1_CH1
12	GPIO3		ADC1_CH2
13	GPIO4		ADC1_CH3
14	GPIO5		ADC1_CH4
15	GPIO6		ADC1_CH5
17	GPIO8	PAD_COMP0	
18	GPIO9	PAD_COMP1	
22	GPIO13	USB_D-	
23	GPIO14	USB_D+	
29	GPIO19	VDD_SPI	

¹ This column lists the GPIO names, since analog functions are configured with GPIO registers that use GPIO numbering.

² **Bold** marks the default pin functions in SPI Boot mode. For more information about the default boot mode, see Section 3.1 *Chip Boot Mode Control*.

³ Regarding **highlighted** cells, see Section 2.3.4 *Restrictions for GPIOs and LP GPIOs*.

2.3.4 Restrictions for GPIOs and LP GPIOs

All IO pins of the ESP32-C5 have GPIO and some have LP GPIO pin functions. However, the IO pins are multiplexed and can be configured for different purposes based on the requirements. Some IOs have restrictions for usage. It is essential to consider the multiplexed nature and the limitations when using these IO pins.

In the tables of this chapter, some pin functions are highlighted in red or highlighted in yellow. These functions indicate pins that require extra caution when used as GPIO / GPIO :

- **IO pins** – allocated for communication with in-package flash/PSRAM and NOT recommended for other uses. For details, see Section [2.6 Pin Mapping Between Chip and Flash/PSRAM](#).
- **IO pins** – have one of the following important functions:
 - **Strapping pins** – need to be at certain logic levels at startup. See Section [3 Boot Configurations](#).

Note:

Strapping pins are highlighted by *Pin Name* or configurations *At Reset*, instead of the pin functions.

- **USB_D+/-** – by default, connected to the USB Serial/JTAG controller. To function as GPIOs, these pins need to be reconfigured.
- **JTAG interface** – often used for debugging. See Table [2-2 Peripheral Signals Routed via HP IO MUX](#). To free these pins up, the pin functions USB_D+/- of the USB Serial/JTAG controller can be used instead. See also Section [3.4 JTAG Signal Source Control](#).
- **UART0 interface** – often used for debugging. See Table [2-2 Peripheral Signals Routed via HP IO MUX](#).
- **SDIO interface** – multiplexed with the pins for the USB Serial/JTAG controller. The SDIO Slave controller can be used together with the USB Serial/JTAG controller in single SPI mode, but not in quad SPI mode.
- **VDD_SPI** – the power supply pin for flash by default, and can only be used as a GPIO pin if the flash is powered by an external power supply.

For more information about assigning pins, please see Section [2.3.5 Peripheral Pin Assignment](#) and [ESP32-C5 Consolidated Pin Overview](#).

2.3.5 Peripheral Pin Assignment

Table 2-8 *Peripheral Pin Assignment* highlights which pins can be assigned to each peripheral interface according to the following priorities:

- **Priority 1 (P1)** : Fixed pins connected directly to peripheral signals via HP IO MUX or LP IO MUX.
If a peripheral interface does not have priority 1 pins, it can be assigned to any GPIO pins from priority 2 to priority 4.
- Any GPIO pins mapping to peripheral signals via GPIO Matrix, can be priority 2, 3, or 4.
 - **Priority 2 (P2)** : GPIO pins can be freely used without restrictions.
 - **Priority 3 (P3)** : GPIO pins should be used with caution, as they may conflict with the following important functions described in Section 2.3.4 *Restrictions for GPIOs and LP GPIOs*:
 - * **GPIO2, GPIO3, GPIO7, GPIO25, GPIO26, GPIO27, GPIO28** : Strapping pins.
 - * **GPIO13, GPIO14** : USB Serial/JTAG interface.
 - * **GPIO2, GPIO3, GPIO4, GPIO5** : JTAG interface.
 - * **GPIO11, GPIO12** : UART0 interface.
 - * **GPIO27** : The VDD_SPI pin. The power supply pin for off-package flash by default, and can only be reconfigured as a GPIO pin if the flash is powered by an external power supply.
 - **Priority 4 (P4)** : GPIO pins already allocated or not recommended for use, as described in Section 2.3.4 *Restrictions for GPIOs and LP GPIOs*:
 - * **GPIO15 ~ GPIO18, GPIO20 ~ GPIO22** : SPI0/1 pins for the off-package flash and PSRAM and not recommended for general GPIO use.

If a peripheral interface does not have priority 2 to 4 pins, such as USB Serial/JTAG, it means it can be assigned only to priority 1 pins.

Note:

- For details about which peripheral signals are connected to HP IO MUX or LP IO MUX pins, please refer to Section 2.3.1 *HP IO MUX Functions* or Section 2.3.2 *LP IO MUX Functions*.
- For details about which peripheral signals can be assigned to GPIO pins, please refer to [ESP32-C5 Technical Reference Manual](#) > Chapter IO MUX and GPIO Matrix > Section HP Peripheral Signal List.

Table 2-8. Peripheral Pin Assignment

Pin No.	Pin Name	USB Serial/JTAG ¹	JTAG	SDIO Slave	ADC	Analog Voltage Comparator	LP UART	LP I2C	UART0 ²	UART1 ²	SPIO/1	SPI2 ²	I2C	CAN FD	LED PWM	I2S	MCPWM	RMT	PCNT	PARLIO	
1	VDDA6																				
2	GND																				
3	VDDA7																				
4	XTAL_N																				
5	XTAL_P																				
6	VDDA8																				
7	CHIP_PU																				
8	VDDPST1																				
9	XTAL_32K_P																				
10	XTAL_32K_N						LP_UART_DTRN (P1)		GPIO0 (P2)	GPIO0 (P2)	GPIO0 (P2)	GPIO0 (P2)	GPIO0 (P2)	GPIO0 (P2)	GPIO0 (P2)	GPIO0 (P2)	GPIO0 (P2)	GPIO0 (P2)	GPIO0 (P2)	GPIO0 (P2)	GPIO0 (P2)
11	MTMS		MTMS (P1)		ADC1_CH0 (P1)		LP_UART_DSRN (P1)		GPIO1 (P2)	GPIO1 (P2)	GPIO1 (P2)	GPIO1 (P2)	GPIO1 (P2)	GPIO1 (P2)	GPIO1 (P2)	GPIO1 (P2)	GPIO1 (P2)	GPIO1 (P2)	GPIO1 (P2)	GPIO1 (P2)	GPIO1 (P2)
12	MTDI		MTDI (P1)		ADC1_CH1 (P1)		LP_UART_RTSN (P1)	LP_I2C_SDA (P1)	GPIO2 (P3)	GPIO2 (P3)	GPIO2 (P3)	FSPIQ (P1)	GPIO2 (P3)	GPIO2 (P3)	GPIO2 (P3)	GPIO2 (P3)	GPIO2 (P3)	GPIO2 (P3)	GPIO2 (P3)	GPIO2 (P3)	GPIO2 (P3)
13	MTCK		MTCK (P1)		ADC1_CH2 (P1)		LP_UART_CTSN (P1)	LP_I2C_SCL (P1)	GPIO3 (P3)	GPIO3 (P3)	GPIO3 (P3)	GPIO3 (P3)	GPIO3 (P3)	GPIO3 (P3)	GPIO3 (P3)	GPIO3 (P3)	GPIO3 (P3)	GPIO3 (P3)	GPIO3 (P3)	GPIO3 (P3)	GPIO3 (P3)
14	MTDO		MTDO (P1)		ADC1_CH3 (P1)		LP_UART_RXD (P1)		GPIO4 (P3)	GPIO4 (P3)	GPIO4 (P3)	FSPiHD (P1)	GPIO4 (P3)	GPIO4 (P3)	GPIO4 (P3)	GPIO4 (P3)	GPIO4 (P3)	GPIO4 (P3)	GPIO4 (P3)	GPIO4 (P3)	GPIO4 (P3)
15	GPIO6				ADC1_CH4 (P1)		LP_UART_TXD (P1)		GPIO5 (P3)	GPIO5 (P3)	GPIO5 (P3)	FSPiWP (P1)	GPIO5 (P3)	GPIO5 (P3)	GPIO5 (P3)	GPIO5 (P3)	GPIO5 (P3)	GPIO5 (P3)	GPIO5 (P3)	GPIO5 (P3)	GPIO5 (P3)
16	GPIO7			SDIO_DATA1 (P1)	ADC1_CH5 (P1)				GPIO6 (P2)	GPIO6 (P2)	GPIO6 (P2)	FSPiCLK (P1)	GPIO6 (P2)	GPIO6 (P2)	GPIO6 (P2)	GPIO6 (P2)	GPIO6 (P2)	GPIO6 (P2)	GPIO6 (P2)	GPIO6 (P2)	GPIO6 (P2)
17	GPIO8			SDIO_DATA0 (P1)		PAD_COMPO (P1)			GPIO7 (P3)	GPIO7 (P3)	GPIO7 (P3)	FSPiD (P1)	GPIO7 (P3)	GPIO7 (P3)	GPIO7 (P3)	GPIO7 (P3)	GPIO7 (P3)	GPIO7 (P3)	GPIO7 (P3)	GPIO7 (P3)	GPIO7 (P3)
18	GPIO9			SDIO_CLK (P1)		PAD_COMP1 (P1)			GPIO8 (P2)	GPIO8 (P2)	GPIO8 (P2)	GPIO8 (P2)	GPIO8 (P2)	GPIO8 (P2)	GPIO8 (P2)	GPIO8 (P2)	GPIO8 (P2)	GPIO8 (P2)	GPIO8 (P2)	GPIO8 (P2)	GPIO8 (P2)
19	GPIO10			SDIO_CMD (P1)					GPIO9 (P2)	GPIO9 (P2)	GPIO9 (P2)	GPIO9 (P2)	GPIO9 (P2)	GPIO9 (P2)	GPIO9 (P2)	GPIO9 (P2)	GPIO9 (P2)	GPIO9 (P2)	GPIO9 (P2)	GPIO9 (P2)	GPIO9 (P2)
20	UOTXD								GPIO10 (P2)	GPIO10 (P2)	GPIO10 (P2)	FSPiCS0 (P1)	GPIO10 (P2)	GPIO10 (P2)	GPIO10 (P2)	GPIO10 (P2)	GPIO10 (P2)	GPIO10 (P2)	GPIO10 (P2)	GPIO10 (P2)	GPIO10 (P2)
21	UORXD								GPIO11 (P3)	GPIO11 (P3)	GPIO11 (P3)	GPIO11 (P3)	GPIO11 (P3)	GPIO11 (P3)	GPIO11 (P3)	GPIO11 (P3)	GPIO11 (P3)	GPIO11 (P3)	GPIO11 (P3)	GPIO11 (P3)	GPIO11 (P3)
22	GPIO13	USB_D- (P1)		SDIO_DATA3 (P1)					GPIO12 (P3)	GPIO12 (P3)	GPIO12 (P3)	GPIO12 (P3)	GPIO12 (P3)	GPIO12 (P3)	GPIO12 (P3)	GPIO12 (P3)	GPIO12 (P3)	GPIO12 (P3)	GPIO12 (P3)	GPIO12 (P3)	GPIO12 (P3)
23	GPIO14	USB_D+ (P1)		SDIO_DATA2 (P1)					GPIO13 (P3)	GPIO13 (P3)	GPIO13 (P3)	GPIO13 (P3)	GPIO13 (P3)	GPIO13 (P3)	GPIO13 (P3)	GPIO13 (P3)	GPIO13 (P3)	GPIO13 (P3)	GPIO13 (P3)	GPIO13 (P3)	GPIO13 (P3)
24	VDDPST2								GPIO14 (P3)	GPIO14 (P3)	GPIO14 (P3)	GPIO14 (P3)	GPIO14 (P3)	GPIO14 (P3)	GPIO14 (P3)	GPIO14 (P3)	GPIO14 (P3)	GPIO14 (P3)	GPIO14 (P3)	GPIO14 (P3)	GPIO14 (P3)
25	SPICS1								GPIO15 (P4)	GPIO15 (P4)	SPICS1 (P1)	GPIO15 (P4)	GPIO15 (P4)	GPIO15 (P4)	GPIO15 (P4)	GPIO15 (P4)	GPIO15 (P4)	GPIO15 (P4)	GPIO15 (P4)	GPIO15 (P4)	GPIO15 (P4)
26	SPICS0								GPIO16 (P4)	GPIO16 (P4)	SPICS0 (P1)	GPIO16 (P4)	GPIO16 (P4)	GPIO16 (P4)	GPIO16 (P4)	GPIO16 (P4)	GPIO16 (P4)	GPIO16 (P4)	GPIO16 (P4)	GPIO16 (P4)	GPIO16 (P4)
27	SPIQ								GPIO17 (P4)	GPIO17 (P4)	SPIQ (P1)	GPIO17 (P4)	GPIO17 (P4)	GPIO17 (P4)	GPIO17 (P4)	GPIO17 (P4)	GPIO17 (P4)	GPIO17 (P4)	GPIO17 (P4)	GPIO17 (P4)	GPIO17 (P4)
28	SPIWP								GPIO18 (P4)	GPIO18 (P4)	SPIWP (P1)	GPIO18 (P4)	GPIO18 (P4)	GPIO18 (P4)	GPIO18 (P4)	GPIO18 (P4)	GPIO18 (P4)	GPIO18 (P4)	GPIO18 (P4)	GPIO18 (P4)	GPIO18 (P4)
29	VDD_SPI								GPIO19 (P3)	GPIO19 (P3)	GPIO19 (P3)	GPIO19 (P3)	GPIO19 (P3)	GPIO19 (P3)	GPIO19 (P3)	GPIO19 (P3)	GPIO19 (P3)	GPIO19 (P3)	GPIO19 (P3)	GPIO19 (P3)	GPIO19 (P3)
30	SPIHD								GPIO20 (P4)	GPIO20 (P4)	SPIHD (P1)	GPIO20 (P4)	GPIO20 (P4)	GPIO20 (P4)	GPIO20 (P4)	GPIO20 (P4)	GPIO20 (P4)	GPIO20 (P4)	GPIO20 (P4)	GPIO20 (P4)	GPIO20 (P4)
31	SPICLK								GPIO21 (P4)	GPIO21 (P4)	SPICLK (P1)	GPIO21 (P4)	GPIO21 (P4)	GPIO21 (P4)	GPIO21 (P4)	GPIO21 (P4)	GPIO21 (P4)	GPIO21 (P4)	GPIO21 (P4)	GPIO21 (P4)	GPIO21 (P4)
32	SPID								GPIO22 (P4)	GPIO22 (P4)	SPID (P1)	GPIO22 (P4)	GPIO22 (P4)	GPIO22 (P4)	GPIO22 (P4)	GPIO22 (P4)	GPIO22 (P4)	GPIO22 (P4)	GPIO22 (P4)	GPIO22 (P4)	GPIO22 (P4)
33	GPIO23								GPIO23 (P2)	GPIO23 (P2)	GPIO23 (P2)	GPIO23 (P2)	GPIO23 (P2)	GPIO23 (P2)	GPIO23 (P2)	GPIO23 (P2)	GPIO23 (P2)	GPIO23 (P2)	GPIO23 (P2)	GPIO23 (P2)	GPIO23 (P2)
34	GPIO24								GPIO24 (P2)	GPIO24 (P2)	GPIO24 (P2)	GPIO24 (P2)	GPIO24 (P2)	GPIO24 (P2)	GPIO24 (P2)	GPIO24 (P2)	GPIO24 (P2)	GPIO24 (P2)	GPIO24 (P2)	GPIO24 (P2)	GPIO24 (P2)
35	GPIO25								GPIO25 (P3)	GPIO25 (P3)	GPIO25 (P3)	GPIO25 (P3)	GPIO25 (P3)	GPIO25 (P3)	GPIO25 (P3)	GPIO25 (P3)	GPIO25 (P3)	GPIO25 (P3)	GPIO25 (P3)	GPIO25 (P3)	GPIO25 (P3)
36	GPIO26								GPIO26 (P3)	GPIO26 (P3)	GPIO26 (P3)	GPIO26 (P3)	GPIO26 (P3)	GPIO26 (P3)	GPIO26 (P3)	GPIO26 (P3)	GPIO26 (P3)	GPIO26 (P3)	GPIO26 (P3)	GPIO26 (P3)	GPIO26 (P3)
37	GPIO27								GPIO27 (P3)	GPIO27 (P3)	GPIO27 (P3)	GPIO27 (P3)	GPIO27 (P3)	GPIO27 (P3)	GPIO27 (P3)	GPIO27 (P3)	GPIO27 (P3)	GPIO27 (P3)	GPIO27 (P3)	GPIO27 (P3)	GPIO27 (P3)
38	GPIO28								GPIO28 (P3)	GPIO28 (P3)	GPIO28 (P3)	GPIO28 (P3)	GPIO28 (P3)	GPIO28 (P3)	GPIO28 (P3)	GPIO28 (P3)	GPIO28 (P3)	GPIO28 (P3)	GPIO28 (P3)	GPIO28 (P3)	GPIO28 (P3)
39	VDDPST3																				
40	VDDA1																				
41	VDDA2																				
42	ANT_2G																				
43	GND																				
44	VDDA3																				
45	VDDA4																				
46	VDDA5																				
47	GND																				
48	ANT_5G																				

¹ For USB Serial/JTAG, the USB_D- and USB_D+ can be swapped by configuring the USB_SERIAL_JTAG_EXCHG_PINS bit according to [ESP32-C5 Technical Reference Manual](#).

² Signals of UART0, UART1, and SPI2 interfaces can be mapped to any GPIO pins through the GPIO Matrix, regardless of whether they are directly routed to [fixed pins](#) via IO MUX.

2.4 Analog Pins

Table 2-9. Analog Pins

QFN48 Pin No.	Pin Name	Pin Type	Pin Function
4	XTAL_N	—	External clock input/output connected to chip's crystal or oscillator. P/N means differential clock positive/negative.
5	XTAL_P	—	
7	CHIP_PU	—	High: On, enables the chip (powered up). Low: Off, the chip powers off (powered down). Note: Do not leave the CHIP_PU pin floating.
42	ANT_2G	I/O	2.4 GHz RF input/output
48	ANT_5G	I/O	5 GHz RF input/output

2.5 Power Supply

2.5.1 Power Pins

The chip is powered via the power pins described in Table 2-10 *Power Pins*.

Table 2-10. Power Pins

QFN48 Pin No.	Pin Name	Direction	Power Supply ^{1,2} Power Domain/Other	IO Pins ⁴
1	VDDA6	Input	Analog power domain 3.3 V	
2	GND	—	External ground connection	
3	VDDA7	Input	Analog power domain 3.3 V	
6	VDDA8	Input	Analog power domain 3.3 V	
8	VDDPST1	Input	LP digital power domain	LP IO
24	VDDPST2	Input	HP digital and part of analog pin power domains	HP IO
29	VDD_SPI ³	Output	Off-package flash	Flash IO
39	VDDPST3	Input	HP digital power domain	HP IO
40	VDDA1	Input	Analog power domain 3.3 V	
41	VDDA2	Input	Analog power domain 3.3 V	
43	GND	—	External ground connection	
44	VDDA3	Input	Analog power domain 3.3 V	
45	VDDA4	Input	Analog power domain 3.3 V	
46	VDDA5	Input	Analog power domain 3.3 V	
47	GND	—	External ground connection	

¹ See in conjunction with Section 2.5.2 *Power Scheme*.

² For recommended and maximum voltage and current, see Section 5.1 *Absolute Maximum Ratings* and Section 5.2 *Recommended Power Supply Characteristics*.

³ To configure VDD_SPI as input or output, see [ESP32-C5 Technical Reference Manual](#) > Chapter *Low-Power Management*.

⁴ LP IO pins are those powered by VDDPST1 and so on, as shown in Figure 2-3 *ESP32-C5 Power Scheme*. See also Table 2-1 *Pin Overview* > Column *Pin Providing Power*.

2.5.2 Power Scheme

The power scheme is shown in Figure 2-3 *ESP32-C5 Power Scheme*.

The components on the chip are powered via voltage regulators.

Table 2-11. Voltage Regulators

Voltage Regulator	Output	Power Supply
HP	1.1 V	HP power domain
LP	1.1 V	LP power domain

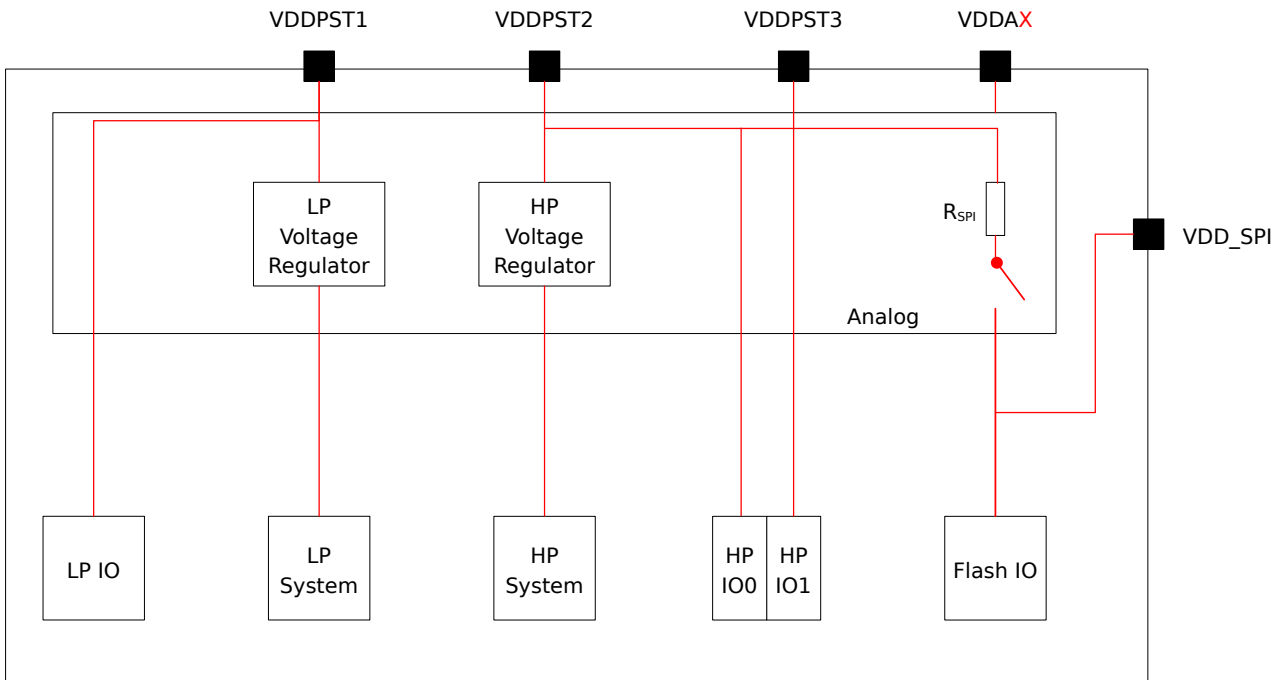

Figure 2-3. ESP32-C5 Power Scheme

2.5.3 Chip Power-up and Reset

Once the power is supplied to the chip, its power rails need a short time to stabilize. After that, CHIP_PU – the pin used for power-up and reset – should be pulled high to activate the chip. For information on CHIP_PU as well as power-up and reset timing, see Figure 2-4 and Table 2-12.

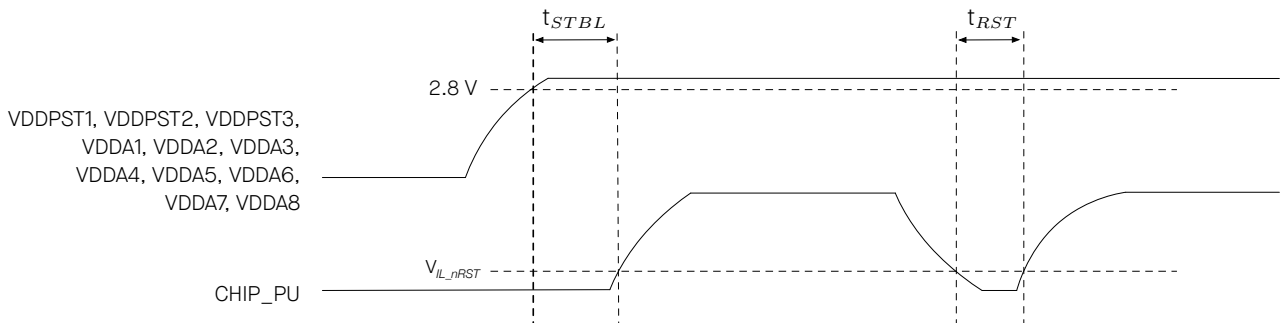

Figure 2-4. Visualization of Timing Parameters for Power-up and Reset

Table 2-12. Description of Timing Parameters for Power-up and Reset

Parameter	Description	Min (μs)
t _{STBL}	Time reserved for the power rails of VDDPST1, VDDPST2, VDDPST3, VDDA1, VDDA2, VDDA3, VDDA4, VDDA5, VDDA6, VDDA7, and VDDA8 to stabilize before the CHIP_PU pin is pulled high to activate the chip	50
t _{RST}	Time reserved for CHIP_PU to stay below V _{IL_nRST} to reset the chip (see Table 5-4)	50

2.6 Pin Mapping Between Chip and Flash/PSRAM

Table 2-13 lists the pin mapping between the chip and off-package flash/PSRAM for all SPI modes. It can also serve as a reference for chip variants with in-package flash/PSRAM.

For more information on SPI controllers, see also Section 4.2.1.2 *SPI Controller*.

Notice: It is not recommended to use the pins connected to flash/PSRAM for any other purposes.

Table 2-13. Pin Mapping Between Chip and Off-Package Flash

QFN48 Pin No.	Pin Name	Single SPI flash	Dual SPI flash	Quad SPI flash
31	SPICLK	CLK	CLK	CLK
26	SPICSO ¹	CS#	CS#	CS#
32	SPID	MOSI	SIO0 ²	SIO0
27	SPIQ	MISO	SIO1	SIO1
28	SPIWP	WP#		SIO2
30	SPIHD	HOLD#		SIO3

¹ SPICSO is used to access flash

² SIO: Serial Data Input and Output

Table 2-14. Pin Mapping Between Chip and Off-Package PSRAM

QFN48 Pin No.	Pin Name	Single SPI PSRAM	Quad SPI PSRAM
31	SPICLK	CLK	CLK
25	SPICS1 ¹	CE#	CE#
32	SPID	SI ²	SIO0
27	SPIQ	SO ³	SIO1
28	SPIWP		SIO2
30	SPIHD		SIO3

¹ SPICS1 is used to access PSRAM

² SI: Serial Data Input, equivalent to MOSI

³ SO: Serial Data Output, equivalent to MISO

3 Boot Configurations

The chip allows for configuring the following boot parameters through strapping pins and eFuse parameters at power-up or a hardware reset, without microcontroller interaction.

- **Chip boot mode**
 - Strapping pin: GPIO26, GPIO27, and GPIO28
- **SDIO sampling and driving clock edge**
 - Strapping pin: GPIO25 and MTDI
- **ROM message printing**
 - Strapping pin: GPIO27
 - eFuse parameter: EFUSE_UART_PRINT_CONTROL and EFUSE_DIS_USB_SERIAL_JTAG_ROM_PRINT
- **JTAG signal source**
 - Strapping pin: GPIO7
 - eFuse parameter: EFUSE_DIS_PAD_JTAG, EFUSE_DIS_USB_JTAG, and EFUSE_JTAG_SEL_ENABLE

The default values of all the above eFuse parameters are 0, which means that they are not burnt. Given that eFuse is one-time programmable, once programmed to 1, it can never be reverted to 0. For how to program eFuse parameters, please refer to [ESP32-C5 Technical Reference Manual](#) > Chapter *eFuse Controller*.

The default values of the strapping pins, namely the logic levels, are determined by pins' internal weak pull-up/pull-down resistors at reset if the pins are not connected to any circuit, or connected to an external high-impedance circuit.

Table 3-1. Default Configuration of Strapping Pins

Strapping Pin	Default Configuration	Bit Value
GPIO25	Floating	–
GPIO26	Floating	–
GPIO27	Pull-up	1
GPIO28	Pull-up	1
GPIO7	Floating	–
MTMS	Floating	–
MTDI	Floating	–

To change the bit values, the strapping pins should be connected to external pull-down/pull-up resistances.

All strapping pins have latches. At Chip Reset, the latches sample the bit values of their respective strapping pins and store them until the chip is powered down or shut down. The states of latches cannot be changed in any other way. It makes the strapping pin values available during the entire chip operation, and the pins are freed up to be used as regular IO pins after reset. For details on Chip Reset, see

[ESP32-C5 Technical Reference Manual](#) > Chapter *Reset and Clock*.

The timing of signals connected to the strapping pins should adhere to the *setup time* and *hold time* specifications in Table 3-2 and Figure 3-1.

Table 3-2. Description of Timing Parameters for the Strapping Pins

Parameter	Description	Min (ms)
t_{SU}	<i>Setup time</i> is the time reserved for the power rails to stabilize before the CHIP_PU pin is pulled high to activate the chip.	0
t_H	<i>Hold time</i> is the time reserved for the chip to read the strapping pin values after CHIP_PU is already high and before these pins start operating as regular IO pins.	3

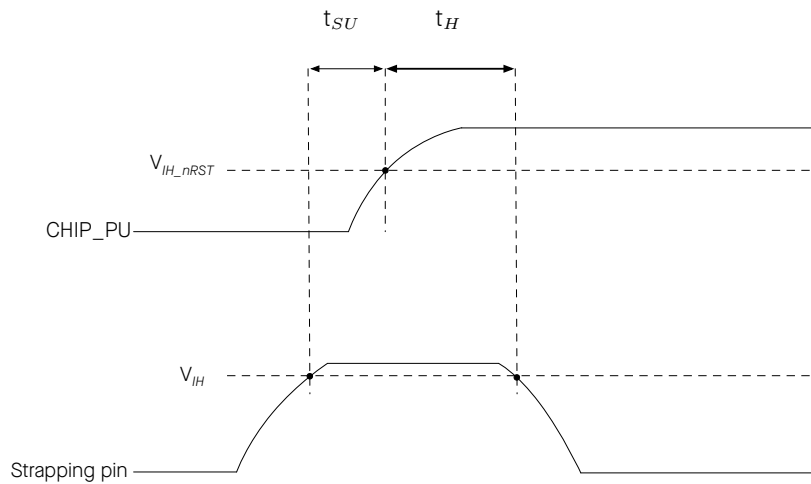

Figure 3-1. Visualization of Timing Parameters for the Strapping Pins

3.1 Chip Boot Mode Control

GPIO26, GPIO27, and GPIO28 control the boot mode after the reset is released. See Table 3-3 *Chip Boot Mode Control*.

Table 3-3. Chip Boot Mode Control

Boot Mode	GPIO26	GPIO27	GPIO28
SPI boot mode ¹	Any value	Any value	1 ¹
Joint download boot mode 0 ²	Any value	1	0
Joint download boot mode 1 ³	0	0	0

¹ **Bold** marks the default value and configuration.

² Joint Download Boot 0 mode supports the following download methods:

- USB-Serial-JTAG Download Boot
- UART Download Boot
- SPI Slave Download Boot (chip revision v0.1 only)

³ Joint Download Boot 1 mode supports the following download methods:

- UART Download Boot
- SDIO Download Boot

In SPI Boot mode, the ROM bootloader loads and executes the program from SPI flash to boot the system.

In Joint Download Boot 0 mode, users can download binary files into flash using UART0, USB, or SPI Slave interfaces. It is also possible to download binary files into SRAM and execute them from SRAM.

In Joint Download Boot 1 mode, users can download binary files into flash using UART0 or SDIO interfaces. It is also possible to download binary files into SRAM and execute them from SRAM.

3.2 SDIO Sampling and Driving Clock Edge Control

The strapping pins GPIO25 and MTDI can be used to decide on which clock edge to sample signals and drive output lines. See Table 3-4 *SDIO Input Sampling Edge/Output Driving Edge Control*.

Table 3-4. SDIO Input Sampling Edge/Output Driving Edge Control

Edge behavior	GPIO25	MTDI
Falling edge sampling, falling edge output	0	0
Falling edge sampling, rising edge output	0	1
Rising edge sampling, falling edge output	1	0
Rising edge sampling, rising edge output	1	1

¹ GPIO25 and MTDI are floating by default, so above are not default configurations.

3.3 ROM Messages Printing Control

During the boot process, the messages by the ROM code can be printed to:

- **(Default) UART0 and USB Serial/JTAG controller**
- UART0
- USB Serial/JTAG controller

EFUSE_UART_PRINT_CONTROL and GPIO27 control ROM messages printing to **UART0** as shown in Table 3-5 *UART0 ROM Message Printing Control*.

Table 3-5. UART0 ROM Message Printing Control

UART0 ROM Message Printing	Register ²	eFuse ³	GPIO27	
ROM messages are always printed to UART0 during boot	0	0 (0b00)	x ⁴	
Print is enabled during boot		1 (0b01)	0	
Print is disabled during boot			1	
Print is disabled during boot			0	
Print is enabled during boot			1	
Print is disabled during boot			3 (0b11)	x
Print is disabled during boot		1	x	x

¹ **Bold** marks the default value and configuration.

² Register: LP_AON_STORE4_REG[0]

³ eFuse: EFUSE_UART_PRINT_CONTROL

⁴ x: x indicates that the value has no effect on the result and can be ignored.

EFUSE_DIS_USB_SERIAL_JTAG_ROM_PRINT controls the printing to **USB Serial/JTAG controller** as shown in Table 3-6 *USB Serial/JTAG ROM Message Printing Control*.

Table 3-6. USB Serial/JTAG ROM Message Printing Control

USB Serial/JTAG ROM Code Printing	EFUSE_DIS_USB_SERIAL_JTAG_ROM_PRINT
Enabled	0
Disabled	1
	Ignored

¹ **Bold** marks the default value and configuration.

3.4 JTAG Signal Source Control

The strapping pin GPIO7 can be used to control the source of JTAG signals during the early boot process. This pin does not have any internal pull resistors and the strapping value must be controlled by the external circuit that cannot be in a high impedance state.

As Table 3-7 *JTAG Signal Source Control* shows, GPIO7 is used in combination with EFUSE_DIS_PAD_JTAG, EFUSE_DIS_USB_JTAG, and EFUSE_JTAG_SEL_ENABLE.

Table 3-7. JTAG Signal Source Control

JTAG Signal Source	eFuse 1 ²	eFuse 2 ³	eFuse 3 ⁴	GPIO7
USB Serial/JTAG Controller ⁶	0	0	0	x ⁵
			1	1
JTAG pins MTDI, MTCK, MTMS, and MTDO			x	0
	1	1	x	x
USB Serial/JTAG Controller ⁶		0		
JTAG is disabled		x		
		1		

¹ **0** marks the default value and configuration.

² eFuse 1: EFUSE_DIS_PAD_JTAG

³ eFuse 2: EFUSE_DIS_USB_JTAG

⁴ eFuse 3: EFUSE_JTAG_SEL_ENABLE

⁵ x: x indicates that the value has no effect on the result and can be ignored.

⁶ In Joint Download Boot 1 mode, the USB Serial/JTAG controller is forcibly disabled, and the JTAG signal only comes from JTAG pins. If PAD_JTAG is also disabled, then JTAG is disabled.

4 Functional Description

4.1 System

This section describes the core of the chip's operation, covering its microprocessor, memory organization, system components, and security features.

4.1.1 Microprocessor and Master

This subsection describes the core processing units within the chip and their capabilities.

4.1.1.1 High-Performance CPU

The ESP-RISC-V CPU (HP CPU) is a high-performance 32-bit core based on the RISC-V instruction set architecture (ISA) comprising base integer (I), multiplication/division (M), atomic (A) and compressed (C) standard extensions.

Feature List

- five-stage pipeline that supports clock frequency of up to 240 MHz
- [RV32IMAC ISA](#) (instruction set architecture)
- two-cycle pipelined multiplier and radix-4 SRT divider
- Zc extensions (Zcb, Zcmp, and Zcmt)
- custom hardware loop instructions (Xhwlp)
- compliant with RISC-V Core Local Interrupt (CLINT)
- compliant with RISC-V Core-Local Interrupt Controller (CLIC)
- branch predictor BHT, BTB, and RAS
- up to 3 hardware breakpoints/watchpoints
- up to 16 PMP/PMA regions
- Machine and User privilege modes
- USB/JTAG for debugging
- compliant with RISC-V debug specification v0.13
- offline trace debug that is compliant with RISC-V Trace Specification v2.0

For details, see [ESP32-C5 Technical Reference Manual](#) > Chapter *High-Performance CPU*.

4.1.1.2 RISC-V Trace Encoder

The RISC-V Trace Encoder in the ESP32-C5 chip provides a way to capture detailed trace information from the High-Performance CPU's execution, enabling deeper analysis and optimization of the system. It connects to the HP CPU's instruction trace interface and compresses the information into smaller packets, which are then stored in internal SRAM.

Feature List

- compatible with Efficient Trace for RISC-V Version 2.0
- synchronization packets sent every few clock cycles or packets
- zero bytes as anchor tags to identify boundaries between data packets
- configurable memory writing mode: loop mode or non-loop mode
- trace lost status to indicate packet loss
- automatic restart after packet loss
- support for delta address mode and full address mode
- support for filter unit

For details, see [ESP32-C5 Technical Reference Manual](#) > Chapter *RISC-V Trace Encoder (TRACE)*.

4.1.1.3 Low-Power CPU

The ESP32-C5 Low-Power CPU (LP CPU) is a 32-bit processor based on the RISC-V ISA comprising integer (I), multiplication/division (M), atomic (A), and compressed (C) standard extensions. It is designed for ultra-low power consumption and is capable of staying powered on during Deep-sleep mode when the HP CPU is powered down.

This LP CPU is designed as a simplified, low-power replacement of HP CPU in sleep modes. It can be also used to supplement the functions of the HP CPU in normal working mode. The LP CPU and LP memory remain powered on in Deep-sleep mode. Hence, the developer can store a program for the LP CPU in the LP memory to access LP IO, LP peripherals, and RTC timers in Deep-sleep mode.

Feature List

- two-stage pipeline that supports a clock frequency of up to 48 MHz
- [RV32IMAC ISA](#) (instruction set architecture)
- 3-4 cycle multiplier and iterative divider
- support for custom vectored interrupts
- up to 2 hardware breakpoints/watchpoints
- JTAG for debugging
- compliant with RISC-V debug specification v0.13
- boot by the CPU, its dedicated timer, or LP IO

For details, see [ESP32-C5 Technical Reference Manual](#) > Chapter *Low-Power CPU*.

4.1.1.4 GDMA Controller

The GDMA Controller is a General Direct Memory Access (GDMA) controller that allows peripheral-to-memory, memory-to-peripheral, and memory-to-memory data transfer without the CPU's intervention. The GDMA has six independent channels, three transmit channels and three receive channels. These channels are shared by peripherals with the GDMA feature, consisting of SPI2, UHCIO, I2S, AES, SHA, ADC, and PARLIO.

Feature List

- programmable length of data to be transferred in bytes
- linked list of descriptors for efficient data transfer management
- INCR4/8/16 burst transfer when accessing the internal RAM or external memory for improved performance
- access to an address space of up to 384 KB in internal RAM
- software-configurable selection of peripheral requesting service
- fixed-priority and round-robin channel arbitration schemes for managing bandwidth
- support for Event Task Matrix

For details, see [ESP32-C5 Technical Reference Manual](#) > Chapter *GDMA Controller (DMA)*.

4.1.2 Memory Organization

This subsection describes the memory arrangement to explain how data is stored, accessed, and managed for efficient operation.

Figure 4-1 illustrates the address mapping structure of ESP32-C5.

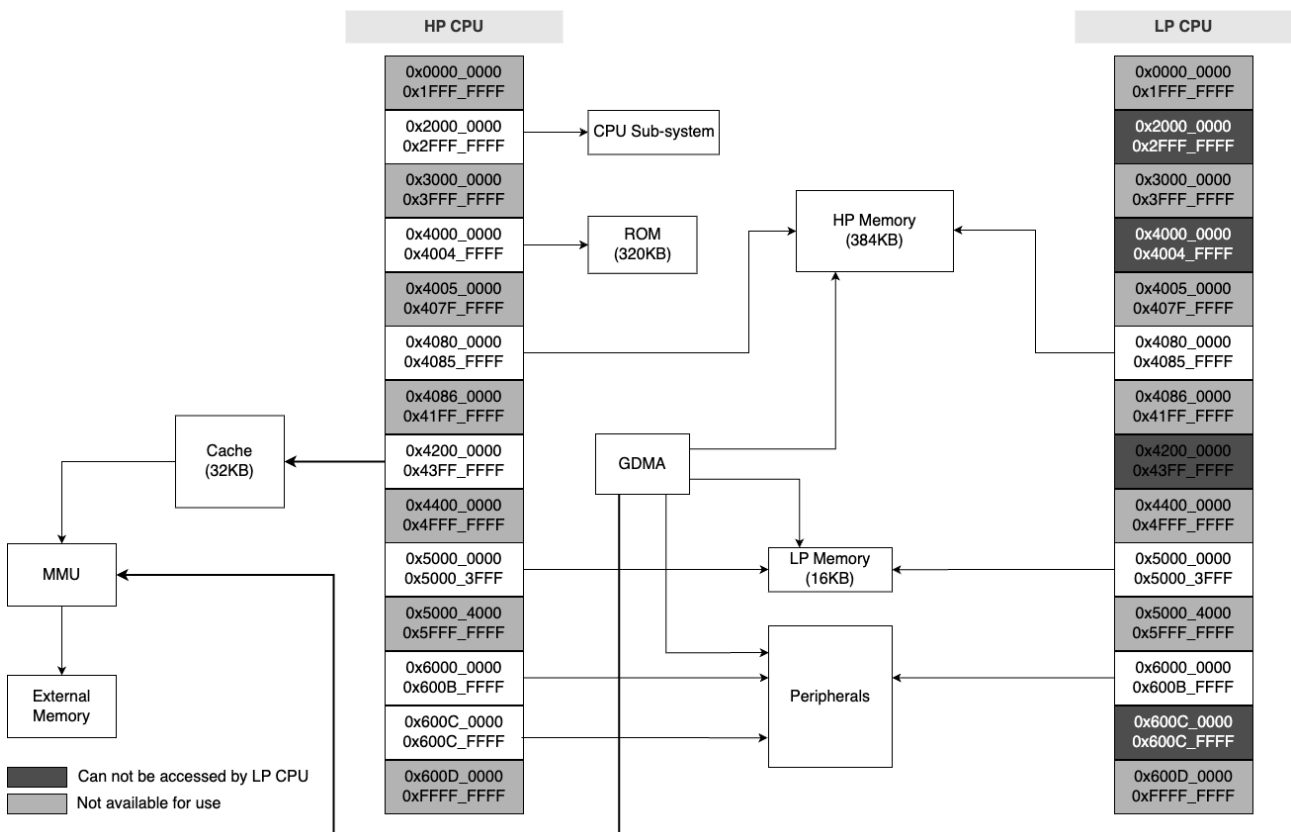

Figure 4-1. Address Mapping Structure

4.1.2.1 Internal Memory

The internal memory of ESP32-C5 refers to the memory integrated on the chip die or in the chip package, including ROM, SRAM, eFuse, and flash.

Feature List

- 320 KB of ROM for booting and core functions
- 384 KB of SRAM for data and instructions
- 16 KB of low-power SRAM (LP SRAM) that can be accessed by HP CPU or LP CPU. It can retain data in Deep-sleep mode
- 4 Kbit of eFuse memory, with 1792 bits available for users. See also Section [4.1.2.3 eFuse Controller](#)
- In-package flash and PSRAM
 - See flash and PSRAM size in Chapter [1 ESP32-C5 Series Information](#)
 - For specifications, refer to Section [5.7 Memory Specifications](#)

For details, see [ESP32-C5 Technical Reference Manual](#) > Chapter *System and Memory*.

4.1.2.2 External Memory

ESP32-C5 supports SPI, Dual SPI, Quad SPI, and QPI interfaces that allow connection to the external flash and PSRAM.

CPU's instruction memory space and read-only data memory space can map into the external flash and PSRAM of ESP32-C5, and the size of the external flash or PSRAM can be 32 MB at most. ESP32-C5 supports hardware encryption/decryption based on XTS-AES to protect developers' programs and data in the external flash and PSRAM.

Feature List

- 32 MB of instruction memory space which can map into the external flash and PSRAM as individual blocks of 64 KB. 32-bit fetch is supported
- 32 MB of data memory space which can map into the external flash and PSRAM as individual blocks of 64 KB. 8-bit, 16-bit, and 32-bit reads are supported by the external flash. 8-bit, 16-bit, and 32-bit reads and writes are supported by the external PSRAM

Note:

After ESP32-C5 is initialized, software can customize the mapping of [off-package flash](#) and PSRAM into the CPU address space.

For details, see [ESP32-C5 Technical Reference Manual](#) > Chapter *System and Memory*.

4.1.2.3 eFuse Controller

The eFuse memory is a one-time programmable memory that stores parameters and user data, and the eFuse controller of ESP32-C5 is used to program and read this eFuse memory.

Feature List

- 4 Kbits in total, with 1792 bits reserved for users, e.g., encryption key and device ID
- one-time programmable storage
- configurable write protection
- configurable read protection
- various hardware encoding schemes to protect against data corruption

For details, see [ESP32-C5 Technical Reference Manual](#) > Chapter *eFuse Controller*.

4.1.2.4 cache

ESP32-C5 has an four-way set associative cache.

Feature List

- size: 32 KB
- block size: 32 bytes
- pre-load function
- lock function
- critical word first and early restart

For details, see [ESP32-C5 Technical Reference Manual](#) > Chapter *Cache*.

4.1.3 System Components

This subsection describes the essential components that contribute to the overall functionality and control of the system.

4.1.3.1 IO MUX and GPIO Matrix

The IO MUX and GPIO Matrix in the ESP32-C5 chip provide flexible routing of peripheral input and output signals to the GPIO pins. These peripherals enhance the functionality and performance of the chip by allowing the configuration of I/O, support for multiplexing, and signal synchronization for peripheral inputs.

Feature List

- 29 GPIO pins for general-purpose I/O or connection to internal peripheral signals
- GPIO matrix:
 - routing 77 peripheral input and 75 output signals to any GPIO pin
 - signal synchronization for peripheral inputs based on IO MUX operating clock
 - GPIO Filter hardware for input signal filtering
- IO MUX for directly connecting certain digital signals (SPI, JTAG, UART) to pins
- support for Event Task Matrix

For details, see [ESP32-C5 Technical Reference Manual](#) > Chapter *IO MUX and GPIO Matrix*.

4.1.3.2 Reset

The ESP32-C5 chip provides four types of reset that occur at different levels, namely CPU Reset, Core Reset, System Reset, and Chip Reset. Except for Chip Reset, all reset types preserve the data stored in internal memory.

Feature List

- four types of reset:
 - CPU reset – resets the CPU core
 - core reset – resets the whole digital system except for the LP system
 - system Reset – resets the whole digital system, including the LP system
 - chip reset – resets the whole chip
- reset trigger:
 - directly by hardware
 - via software by configuring the corresponding registers of the CPU
- support for retrieving reset cause

For details, see [ESP32-C5 Technical Reference Manual](#) > Chapter *Reset and Clock*.

4.1.3.3 Clock

The ESP32-C5 chip has clocks sourced from oscillators, RC circuits, and PLL circuits, which are then processed by dividers or selectors. The clocks can be classified into high-speed clocks for devices working at higher frequencies and slow-speed clocks for low-power systems and some peripherals.

Feature List

- high-speed clocks for HP system
 - external main crystal clock (supports 48 MHz crystal clock frequency)
 - internal fast RC oscillator clock (typically about 20 MHz, and adjustable)
 - PLL clock

Notice:

- * ESP32-C5 is unable to operate without an external main crystal clock.
- * ESP32-C5 can automatically filter out high-frequency glitches from the external main crystal clock.

- slow-speed clocks for RTC counter, RTC watchdog, and the power management unit (PMU)
 - internal slow RC oscillator (typically about 150 kHz)
 - 32 kHz external low-speed crystal clock

- external IO clock (external clock source connected with digital IO)
- fast-speed clocks for low-power peripherals and sensor controllers
 - external main crystal clock divided by 2
 - internal fast RC oscillator clock (typically about 20 MHz, and adjustable)

For details, see [ESP32-C5 Technical Reference Manual](#) > Chapter *Reset and Clock*.

4.1.3.4 Interrupt Matrix

The Interrupt Matrix in the ESP32-C5 chip routes interrupt requests generated by various peripherals to CPU interrupts.

Feature List

- 84 peripheral interrupt sources accepted as input
- 32 CPU peripheral interrupts generated to CPU as output
- current interrupt status query of peripheral interrupt sources
- multiple interrupt sources mapping to a single CPU interrupt (i.e., shared interrupts)

For details, see [ESP32-C5 Technical Reference Manual](#) > Chapter *Interrupt Matrix*.

4.1.3.5 Event Task Matrix

ESP32-C5 integrates an SoC ETM with multiple channels. Each input event on channels is mapped to an output task. Events are generated by peripherals, while tasks are received by peripherals.

Feature List

- up to 50 mapping channels, each connected to an event and a task and controlled independently
- an event or a task can be mapped to any tasks or events in the matrix. That is to say, one event can be mapped to different tasks via multiple channels, or different events can be mapped to the same task via their individual channels
- peripherals supporting ETM consisting of GPIO, LED PWM, general-purpose timers, RTC timer, system timer, MCPWM, temperature sensor, ADC, I2S, LP CPU, GDMA, and PMU

For details, see [ESP32-C5 Technical Reference Manual](#) > Chapter *Event Task Matrix*.

4.1.3.6 Power Management Unit

The ESP32-C5 has an advanced Power Management Unit (PMU). It can be flexibly configured to power up different power domains of the chip to achieve the best balance between chip performance, power consumption, and wakeup latency.

The integrated LP CPU allow the ESP32-C5 to operate in Deep-sleep mode with most of the power domains turned off, thus achieving extremely low-power consumption.

Configuring the PMU is a complex procedure. To simplify power management for typical scenarios, there are the following **predefined power modes** that power up different combinations of power domains:

- **Active mode** – The HP CPU, RF circuits, and all peripherals are on. The chip can process data, receive, transmit, and listen.
- **Modem-sleep mode** – The HP CPU is on, but the clock frequency can be reduced. The wireless connections can be configured to remain active as RF circuits are periodically switched on when required.
- **Light-sleep mode** – The HP CPU stops running, and can be optionally powered on. The LP peripherals, as well as the LP CPU can be woken up periodically by the timer. The chip can be woken up via all wake up mechanisms: MAC, RTC timer, or external interrupts. Wireless connections can remain active. Some groups of digital peripherals can be optionally powered off.
- **Deep-sleep mode** – Only the LP system is powered on. Wireless connection data is stored in LP memory.

For modules powered on in each power mode, see Figure [ESP32-C5 Functional Block Diagram](#).

For power consumption in different power modes, see Section [5.6 Current Consumption](#).

For details, see [ESP32-C5 Technical Reference Manual](#) > Chapter *Low-Power Management*.

4.1.3.7 System Timer

The System Timer (SYSTIMER) in the ESP32-C5 chip is a 52-bit timer that can be used to generate tick interrupts for the operating system or as a general timer to generate periodic or one-time interrupts.

Feature List

- two 52-bit counters and three 52-bit comparators
- counters with an average clock frequency of 16 MHz
- three types of independent interrupts generated according to alarm value
- two alarm modes: target mode and period mode
- 52-bit alarm values and 26-bit alarm periods
- automatic reload of counter value
- counters can be stalled if the CPU is stalled or in OCD mode
- real-time alarm events

For details, see [ESP32-C5 Technical Reference Manual](#) > Chapter *System Timer*.

4.1.3.8 Timer Group

The Timer Group (TIMG) in the ESP32-C5 chip can be used to precisely time an interval, trigger an interrupt after a particular interval (periodically and aperiodically), or act as a hardware clock. ESP32-C5 has two timer groups, TIMG0 and TIMG1, each consisting of one general-purpose timer and one Main System Watchdog Timer.

Feature List

- 16-bit prescaler
- 54-bit time-base counter programmable to incrementing or decrementing

- able to read real-time value of the time-base counter
- halt and resume the time-base counter
- programmable alarm generation
- timer value reload (auto-reload at an alarm or a software-controlled instant reload)
- frequency calculation of slow clock for TIMGO
- level interrupt generation
- real-time alarm events
- support several ETM tasks and events

For details, see [ESP32-C5 Technical Reference Manual](#) > Chapter *Timer Group (TIMG)*.

4.1.3.9 Watchdog Timers

The Watchdog Timers (WDT) in ESP32-C5 are used to detect and recover from malfunctions. The chip contains three digital watchdog timers: one in each of the two timer groups (MWDT) and one in the RTC Module (RWDT). Additionally, there is one analog watchdog timer called the Super watchdog (SWD) that helps prevent the system from operating in a sub-optimal state.

Feature List

- digital watchdog timers:
 - four stages, each with a programmable timeout value. Each stage can be configured, enabled and disabled separately
 - three timeout actions for MWDT: interrupt, CPU reset, or core reset upon expiry of each stage; four timeout actions for RWDT interrupt: CPU reset, core reset, or system reset for RWDT upon expiry of each stage
 - 32-bit expiry counter
 - write protection, to prevent RWDT and MWDT configuration from being altered inadvertently
 - flash boot protection
If the boot process from an SPI flash does not complete within a predetermined period of time, the watchdog will reboot the entire main system
- analog watchdog timer :
 - ultra-low power
 - interrupt to indicate that the SWD is about to time out
 - various dedicated methods for software to feed SWD, which enables SWD to monitor the working state of the whole operating system

For details, see [ESP32-C5 Technical Reference Manual](#) > Chapter *Watchdog Timers*.

4.1.3.10 RTC Timer

ESP32-C5 RTC Timer is a 48-bit readable counter that can operate in any power mode. It is used as a system timer when the timers in the HP system is unavailable. It also allows for configuring timer interrupts and logging the time when specific events happen in the system.

Feature List

- 48-bit counter operating under the RTC clock
- real-time reading of the time-base counter's value
- configurable target value for the counter to trigger an interrupt upon timeout

For details, see [ESP32-C5 Technical Reference Manual](#) > Chapter *RTC Timer*.

4.1.3.11 Permission Control

The Permission Control module in ESP32-C5 is responsible for managing access permissions to memory and peripheral registers. It consists of two parts: PMP (Physical Memory Protection) and APM (Access Permission Management).

Feature List

- access permission management for ROM, HP memory, HP peripheral, and LP peripheral address spaces
- APM supports each master (such as DMA) to select one of the four security modes
- access permission configuration for up to 32 address ranges
- individual permission configuration for each register
- Interrupt function and exception information record

For details, see [ESP32-C5 Technical Reference Manual](#) > Chapter *Permission Control (PMS)*.

4.1.3.12 System Registers

The System Registers in the ESP32-C5 chip are used to configure various auxiliary chip features.

Feature List

- control External memory encryption and decryption
- control CPU core debugging
- control Bus timeout protection

For details, see [ESP32-C5 Technical Reference Manual](#) > Chapter *System Registers (HP_SYSREG)*.

4.1.3.13 Debug Assistant

The Debug Assistant provides a set of functions to help locate bugs and issues during software debugging. It offers various monitoring capabilities and logging features to assist in identifying and resolving software errors efficiently.

Feature List

- read/write monitoring: Monitor whether the CPU bus reads from or writes to a specified memory address space
- stack pointer (SP) monitoring: Prevent stack overflow or erroneous push/pop operations violation will trigger an interrupt.
- program counter (PC) logging: Record PC value. The developer can get the last PC value at the most recent CPU reset
- bus access logging: Record information about bus access when the CPU or DMA writes a specified value

For details, see [ESP32-C5 Technical Reference Manual](#) > Chapter *Debug Assistant (ASSIST_DEBUG)*.

4.1.3.14 Brownout Detector

ESP32-C5 can periodically monitor the voltage of the power supply, and in the event of abnormal voltage, it is capable of generating interrupts or initiating resets.

Feature List

- configurable detection threshold
- configurable reset level
- glitch filtering

For more details, see the [ESP32-C5 Technical Reference Manual](#) > Chapter *Power Supply Detector*.

4.1.4 Cryptography and Security Component

This subsection describes the security features incorporated into the chip, which safeguard data and operations.

4.1.4.1 AES Accelerator

ESP32-C5 integrates an Advanced Encryption Standard (AES) accelerator, which is a hardware device that speeds up computation using AES algorithm significantly, compared to AES algorithms implemented solely in software. The AES accelerator integrated in ESP32-C5 has two working modes, which are typical AES and DMA-AES.

Feature List

- typical AES working mode
 - AES-128/AES-256 encryption and decryption, compliant with [NIST FIPS 197](#)
- DMA-AES working mode
 - AES-128/AES-256 encryption and decryption, compliant with [NIST FIPS 197](#)
 - block cipher mode, compliant with [NIST SP 800-38A](#)
 - * ECB (Electronic Codebook)

- * CBC (Cipher Block Chaining)
 - * OFB (Output Feedback)
 - * CTR (Counter)
 - * CFB8 (8-bit Cipher Feedback)
 - * CFB128 (128-bit Cipher Feedback)
- interrupt generation

For details, see [ESP32-C5 Technical Reference Manual](#) > Chapter *AES Accelerator (AES)*.

4.1.4.2 ECC Accelerator

Elliptic Curve Cryptography (ECC) is an approach to public-key cryptography based on the algebraic structure of elliptic curves. ECC allows smaller keys compared to RSA cryptography while providing equivalent security.

ESP32-C5's ECC Accelerator can complete various calculations based on different elliptic curves, thus accelerating the ECC algorithm and ECC-derived algorithms (such as ECDSA).

Feature List

- three elliptic curves, namely P-192, P-256 and P-384 defined in [FIPS 186-3](#)
- two coordinate systems, namely Affine Coordinates and Jacobian Coordinates
- different point operations, including point addition, point multiplication, and point verification
- different modular operations based on the order or mod base of the curve, including mod addition, mod subtraction, mod multiplication, and mod division
- interrupt upon completion of calculation
- secure operating mode for Base Point Multiplication within a specified time frame

For details, see the [ESP32-C5 Technical Reference Manual](#) > Chapter *ECC Accelerator (ECC)*.

4.1.4.3 HMAC Accelerator

The HMAC Accelerator (HMAC) module is designed to compute Message Authentication Codes (MACs) using the SHA-256 Hash algorithm and keys as described in RFC 2104. It provides hardware support for HMAC computations, significantly reducing software complexity and improving performance.

Feature List

- standard HMAC-SHA-256 algorithm
- hash result only accessible by configurable hardware peripheral (in downstream mode)
- compatibility with challenge-response authentication algorithm
- required keys for RSA_DS (in downstream mode)
- re-enabled soft-disabled JTAG (in downstream mode)

For details, see the [ESP32-C5 Technical Reference Manual](#) > Chapter *HMAC Accelerator*.

4.1.4.4 RSA Accelerator

The RSA accelerator provides hardware support for high-precision computation used in various RSA asymmetric cipher algorithms, significantly improving their run time and reducing their software complexity. Compared with RSA algorithms implemented solely in software, this hardware accelerator can speed up RSA algorithms significantly. The RSA accelerator also supports operands of different lengths, which provides more flexibility during the computation.

Feature List

- large-number modular exponentiation with two optional acceleration options
- large-number modular multiplication, up to 3072 bits
- large-number multiplication, with operands up to 1536 bits
- operands of different lengths
- interrupt on completion of computation

For details, see the [ESP32-C5 Technical Reference Manual](#) > Chapter *RSA Accelerator*.

4.1.4.5 SHA Accelerator

ESP32-C5 integrates an SHA accelerator, which is a hardware device that speeds up the SHA algorithm significantly, compared to SHA algorithms implemented solely in software. The SHA accelerator integrated in ESP32-C5 has two working modes, which are typical SHA and DMA-SHA.

Feature List

- the following hash algorithms introduced in [FIPS PUB 180-4](#)
 - SHA-1
 - SHA-224
 - SHA-256
 - SHA-384
 - SHA-512/224
 - SHA-512/256
 - SHA-512/t
- two working modes
 - typical SHA
 - DMA-SHA
- interleaved function in typical SHA working mode
- interrupt function in DMA-SHA working mode

For more details, see the [ESP32-C5 Technical Reference Manual](#) > Chapter *SHA Accelerator (SHA)*.

4.1.4.6 RSA Digital Signature Peripheral (RSA_DS)

The RSA Digital Signature Peripheral (RSA_DS) is used to verify the authenticity and integrity of a message using a cryptographic algorithm. This can be used to validate a device's identity to a server, or to check the integrity of a message.

ESP32-C5 includes an RSA_DS module providing hardware acceleration of messages' signatures based on RSA. HMAC is used as the key derivation function to output the RSA_DS_KEY key using eFuse as the input key. Subsequently, the RSA_DS peripheral uses RSA_DS_KEY to decrypt the pre-encrypted parameters and calculate the signature. The whole process happens in hardware so that neither the decryption key for the RSA parameters nor the input key for the HMAC key derivation function can be seen by users while calculating the signature.

Feature List

- RSA digital signatures with key length up to 3072 bits
- encrypted private key data, only decryptable by the RSA_DS peripheral
- SHA-256 digest to protect private key data against tampering by an attacker

For more details, see the [ESP32-C5 Technical Reference Manual](#) > Chapter *RSA Digital Signature Peripheral (RSA_DS)*.

4.1.4.7 ECDSA Digital Signature Peripheral (ECDSA_DS)

In cryptography, the ECDSA Digital Signature Peripheral (ECDSA_DS) offers a variant of the Digital Signature Algorithm (DSA) which uses elliptic-curve cryptography.

ESP32-C5's ECDSA_DS provides a secure and efficient environment for computing ECDSA signatures. It offers fast computations while ensuring the confidentiality of the signing process to prevent information leakage. This makes it a valuable tool for applications that require high-speed cryptographic operations with strong security guarantees. By using the ECDSA_DS, users can be confident that their data is being protected without sacrificing performance.

Feature List

- digital signature generation and verification
- public key exportation
- three elliptic curves, namely P-192, P-256, and P-384 defined in [FIPS 186-3](#)
- four hash algorithms for message hash in the ECDSA operation, namely SHA-224, SHA-256, SHA-384, and SHA-512 defined in [FIPS PUB 180-4](#)
- deterministic ECDSA defined in [RFC6979](#).
- high security features:
 - dynamic access permission in different operation statuses to ensure information security, preventing key leakage due to intermediate data leakage
 - fixed-duration signing and verification processes to resist side-channel attacks

For details, see the [ESP32-C5 Technical Reference Manual](#) > Chapter *ECDSA Digital Signature Peripheral (ECDSA_DS)*.

4.1.4.8 External Memory Encryption and Decryption

The ESP32-C5 integrates an External Memory Encryption and Decryption module that complies with the XTS-AES standard algorithm specified in [IEEE Std 1619-2007](#), providing security for users' application code and data stored in the external memory (flash and PSRAM). Users can store proprietary firmware and sensitive data (e.g., credentials for gaining access to a private network) to the off-package flash, and securely run data-sensitive applications in PSRAM.

Feature List

- general XTS-AES algorithm, compliant with [IEEE Std 1619-2007](#)
- software-based manual encryption
- high-speed auto encryption without software
- high-speed auto decryption without software
- encryption and decryption functions jointly enabled/disabled by registers configuration, eFuse parameters, and boot mode
- configurable counter measures against DPA attacks
- flash and PSRAM use their own separate keys

For more details, see the [ESP32-C5 Technical Reference Manual](#) > Chapter *External Memory Encryption and Decryption (XTS_AES)*.

4.1.4.9 True Random Number Generator

The ESP32-C5 contains a true random number generator, which generates 32-bit random numbers that can be used for cryptographical operations, among other things.

Feature List

- RNG entropy source
 - thermal noise from high-speed ADC or SAR ADC
 - an asynchronous clock mismatch

For more details, see the [ESP32-C5 Technical Reference Manual](#) > Chapter *Random Number Generator (RNG)*.

4.1.4.10 Key Manager

The key manager is the security core of the system. They can store and deploy keys securely. The key manager utilizes each chip's unique physical unclonable function (PUF) to generate a hardware unique key (HUK) for that chip, which serves as the chip's root of trust. The HUK is generated automatically each time the chip powers on and disappears when the chip powers off. The key manager thus protects key storage and provisioning by design.

On the ESP32-C5, the key manager stores key information (not the keys in plaintext, but the information needed to recover them) in external memory, enabling flexible key management features such as unlimited number of keys and dynamic key changes.

Feature List

The HUK generator has the following features:

- HUK generation mode:
 - generates a new HUK and its recovery information
- HUK recovery mode:
 - recovers a deployed HUK with its recovery information
- prompt for HUK recovery error
- prompt for HUK risk level

The key manager has the following features:

- unlimited number of keys
- specified private key deployment (AES deploy mode):
 - users specify the value of the key
- negotiated private key deployment (ECDH0 deploy mode):
 - highest security mode: there is no need to worry about the leaks of data in external channels
 - requires chip initiation to obtain the private key
 - negotiates the key value between each chip and the user
- negotiated private key deployment (ECDH1 deploy mode):
 - provides auxiliary key software/scripts to users
 - no need to boot the chip to obtain the private key
- random key deployment (random deploy mode):
 - deploys a hardware-generated random key with nobody knowing the exact value
- private key recovery deployment (private key recovery mode):
 - recovers exactly the same key by entering the key information generated during deployment
- key information export (*key_info* export mode):
 - generates unique key information for the same key each time

For more details, see the [ESP32-C5 Technical Reference Manual](#) > Chapter *Key Manager*.

Note:

This feature is supported by chip revision v1.2 or later.

4.1.4.11 Power Glitch Detector

ESP32-C5 can monitor the voltage of the power supply in real time. When a voltage glitch occurs, the chip will reset immediately to prevent power glitch attacks.

Feature List

- configurable threshold for power glitch (around 2.7 V by default)
- enabled upon power-up

For more details, see the [ESP32-C5 Technical Reference Manual](#) > Chapter *Power Supply Detector*.

4.2 Peripherals

This section describes the chip's peripheral capabilities, covering connectivity interfaces and on-chip sensors that extend its functionality.

4.2.1 Connectivity Interface

This subsection describes the connectivity interfaces on the chip that enable communication and interaction with external devices and networks.

4.2.1.1 UART Controller

ESP32-C5 has three UART interfaces, i.e. UART0, UART1, and LP UART. All the three interfaces provide hardware flow control (CTS and RTS signals) and software flow control (XON and XOFF).

Feature List

- programmable baud rates up to 5 MBaud
- RAM shared by TX FIFOs and RX FIFOs
- support for various lengths of data bits and stop bits
- parity bit support
- special character AT_CMD detection
- RS485 protocol support (not supported by LP UART)
- IrDA protocol support (not supported by LP UART)
- high-speed data communication using GDMA (not supported by LP UART)
- receive timeout feature
- UART as the wake-up source
- software and hardware flow control

For details, see [ESP32-C5 Technical Reference Manual](#) > Chapter *UART Controller (UART)*.

Pin Assignment

For details, see Section [2.3.5 Peripheral Pin Assignment](#).

4.2.1.2 SPI Controller

ESP32-C5 features three SPI interfaces (SPI0, SPI1, and SPI2). SPI0 and SPI1 can be configured to operate in SPI memory mode, while SPI2 can be configured to operate in general-purpose SPI mode.

Feature List

- **SPI Memory mode**

In SPI memory mode, SPI0 and SPI1 interfaces are for external SPI memory. Data are transferred in unit of byte. Up to four-line STR reads and writes are supported. The clock frequency is configurable to a maximum of 120 MHz.

- **SPI2 General-purpose SPI (GP-SPI) mode**

SPI2 can operate in master and slave modes. SPI2 supports two-line full-duplex communication and single/two/four-line half-duplex communication in both master and slave modes. The host's clock frequency is configurable. Data are transferred in unit of byte. The clock polarity (CPOL) and phase (CPHA) are also configurable. The SPI2 interface can connect to GDMA.

- In master mode, the clock frequency is 80 MHz at most, and the four modes of SPI transfer format are supported.
- In slave mode, the clock frequency is 40 MHz at most, and the four modes of SPI transfer format are also supported.

For details, see [ESP32-C5 Technical Reference Manual](#) > Chapter *SPI Controller (SPI)*.

Pin Assignment

For details, see Section [2.3.5 Peripheral Pin Assignment](#).

4.2.1.3 I2C Controller

ESP32-C5 has an I2C and an LP I2C bus interface. I2C is used for I2C master mode or slave mode, depending on your configuration, while LP I2C is always in master mode.

Feature List

- standard mode (100 Kbit/s)
- fast mode (400 Kbit/s)
- up to 800 Kbit/s (constrained by SCL and SDA pull-up strength)
- 7-bit and 10-bit addressing mode
- double addressing mode
- 7-bit broadcast address

For details, see [ESP32-C5 Technical Reference Manual](#) > Chapter *I2C Controller (I2C)*.

Pin Assignment

For details, see Section [2.3.5 Peripheral Pin Assignment](#).

4.2.1.4 I2S Controller

ESP32-C5 includes a standard I2S interface. This interface can operate as a master or a slave in full-duplex mode or half-duplex mode, and supports 8-bit, 16-bit, 24-bit, or 32-bit serial communication. BCK clock frequency, from 10 kHz up to 40 MHz, is supported.

The I2S interface supports TDM Philips, TDM MSB alignment, TDM PCM standard, PDM standard, and PCM-to-PDM TX interface. It connects to the GDMA controller.

Feature List

- master mode and slave mode
- full-duplex and half-duplex communications
- separate TX and RX units that can work independently or simultaneously
- a variety of audio standards supported:
 - TDM Philips standard
 - TDM MSB alignment standard
 - TDM PCM standard
 - PDM standard
- various TX/RX modes
 - TDM TX mode, up to 16 channels supported
 - TDM RX mode, up to 16 channels supported
 - PDM TX mode
 - * raw PDM data transmission
 - * PCM-to-PDM data format conversion, up to 2 channels supported
 - PDM RX mode
 - * raw PDM data reception
- configurable clock source with frequency up to 240 MHz
- configurable high-precision sample clock with a variety of sampling frequencies supported
- 8/16/24/32-bit data width
- synchronous counter in TX mode
- ETM feature
- direct memory access
- standard I2S interface interrupts

For details, see [ESP32-C5 Technical Reference Manual](#) > Chapter *I2S Controller (I2S)*.

Pin Assignment

For details, see Section [2.3.5 Peripheral Pin Assignment](#).

4.2.1.5 USB Serial/JTAG Controller

ESP32-C5 contains a USB Serial/JTAG controller. This unit can be used to program the SoC's flash, read program output, as well as attach a debugger to the running program. All of these are possible for any computer with a USB host without any active external components.

Feature List

- USB 2.0 full speed compliant, capable of up to 12 Mbit/s transfer speed (note that this controller does not support the faster 480 Mbit/s high-speed transfer mode)
- CDC-ACM virtual serial port and JTAG adapter functionality
- programming the chip's flash
- CPU debugging with compact JTAG instructions
- a full-speed USB PHY integrated in the chip

For details, see [ESP32-C5 Technical Reference Manual](#) > Chapter *USB Serial/JTAG Controller (USB_SERIAL_JTAG)*.

Pin Assignment

For details, see Section [2.3.5 Peripheral Pin Assignment](#).

4.2.1.6 CAN FD Controller

The CAN FD is a multi-master multi-cast communication protocol. The CAN FD controller facilitates the communication based on this protocol.

Feature List

- compliant with ISO11898-1:2015
- RX buffer FIFO with 128 words (6 CAN FD frames with 64-byte data payloads, 21 CAN/CAN FD frames with 8-byte data payloads)
- 4 TX buffers (1 CAN FD frame in each TX buffer)
- 32-bit APB interface
- support of ISO and non-ISO CAN FD protocol
- timestamping and time triggered transmission
- three single-bit filters and one range filter
- support interrupts
- loopback, bus monitoring, ACK forbidden, self test, and restricted operation modes

For details, see [ESP32-C5 Technical Reference Manual](#) > Chapter *Controller Area Network Flexible Data-Rate*.

Pin Assignment

For details, see Section [2.3.5 Peripheral Pin Assignment](#).

4.2.1.7 LED PWM Controller

The LED PWM controller can generate independent digital waveform on six channels.

Feature List

- generating digital waveform with configurable periods and duty cycle. The resolution of duty cycle can be up to 20 bits
- multiple clock sources, including 80 MHz PLL clock, external main crystal clock, and internal fast RC oscillator
- operation when the CPU is in Light-sleep mode
- gradual increase or decrease of duty cycle, which is useful for the LED RGB color-gradient generator
- up to 16 duty cycle ranges for gamma curve generation, each can be independently configured in terms of duty cycle direction (increase or decrease), step size, the number of steps, and step frequency

For details, see [ESP32-C5 Technical Reference Manual](#) > Chapter *LED PWM Controller*.

Pin Assignment

For details, see Section [2.3.5 Peripheral Pin Assignment](#).

4.2.1.8 Pulse Count Controller

The Pulse Count controller (PCNT) in ESP32-C5 captures pulses and counts pulse edges in seven modes.

Feature List

- four independent pulse counters (units) that count from 1 to 65535
- each unit consists of two independent channels sharing one pulse counter
- all channels have input pulse signals (e.g. `sig_ch0_un`) with their corresponding control signals (e.g. `ctrl_ch0_un`)
- independently filter glitches of input pulse signals (`sig_ch0_un` and `sig_ch1_un`) and control signals (`ctrl_ch0_un` and `ctrl_ch1_un`) on each unit
- each channel has the following parameters:
 1. selection between counting on positive or negative edges of the input pulse signal
 2. configuration to Increment, Decrement, or Disable counter mode for control of signal's high and low states
- support step counting
- maximum frequency of pulses: 40 MHz

For details, see [ESP32-C5 Technical Reference Manual](#) > Chapter *Pulse Count Controller*.

Pin Assignment

For details, see Section [2.3.5 Peripheral Pin Assignment](#).

4.2.1.9 Motor Control PWM

ESP32-C5 integrates an MCPWM that can be used to drive digital motors and smart light.

Feature List

- a clock divider (prescaler), three PWM timers, three PWM operators, and a dedicated capture submodule. PWM timers are used to generate timing references. PWM operators generate desired waveform based on the timing references
- a PWM operator can use the timing reference of any PWM timer
- a PWM operator can use the same timing reference with other PWM operators
- PWM operators can use different PWM timers' values to produce independent PWM signals
- PWM timers can be synchronized

For details, see [ESP32-C5 Technical Reference Manual](#) > Chapter *Motor Control PWM (MCPWM)*.

Pin Assignment

For details, see Section [2.3.5 Peripheral Pin Assignment](#).

4.2.1.10 Remote Control Peripheral

The Remote Control Peripheral (RMT) supports two channels of infrared remote transmission and two channels of infrared remote reception. By controlling pulse waveform through software, it supports various infrared and other single wire protocols.

Feature List

- four channels:
 - TX channels 0 ~ 1
 - RX channels 2 ~ 3
 - four channels share a 192 x 32-bit RAM
- the transmitter supports:
 - normal TX mode
 - wrap TX mode
 - modulation on TX pulses
 - continuous TX mode
 - multiple channels (programmable) transmitting data simultaneously

- the receiver supports:
 - normal RX mode
 - wrap RX mode
 - RX filtering
 - demodulation on RX pulses

For more details, see [ESP32-C5 Technical Reference Manual](#) > Chapter *Remote Control Peripheral (RMT)*.

Pin Assignment

For details, see Section [2.3.5 Peripheral Pin Assignment](#).

4.2.1.11 Parallel IO Controller

ESP32-C5 integrates a PARLIO controller for parallel data transfer. It has a transmitter and a receiver, connected with the GDMA controller. In full-duplex mode the PARLIO controller supports up to 4-bit parallel data transfer, while in half-duplex mode it supports up to 8-bit parallel data transfer.

Feature List

- multiple clock sources and clock division, with clock frequency up to 40 MHz
- receiver/transmitter supports input and output clock inverse
- 1/2/4/8-bit data transfer
- changeable sample sequence for data to be transmitted and received in 1-bit, 2-bit, and 4-bit mode
- support for multiple data sampling mode by the receiver
- support for multiple GDMA EOF signal generation modes by the receiver
- output external chip select signals with configurable delay cycles
- support for transmitter clock gating

For more details, see [ESP32-C5 Technical Reference Manual](#) > Chapter *Parallel IO Controller*.

Pin Assignment

For details, see Section [2.3.5 Peripheral Pin Assignment](#).

4.2.1.12 BitScrambler

The ESP32-C5 has an extensive amount of DMA-capable peripherals. These can move data from memory to an external device, and vice versa, without any interference from the CPU. This only works if the external device needs or emits the data in question in the same format as the software expects it: if not, the CPU needs to rewrite the format of the data. Examples include a need to swap bytes, reverse bytes, and shift the data left or right.

As bitwise operations tend to be fairly CPU-expensive and the purpose of DMA is to not use the CPU in the transfer, ESP32-C5 integrates one BitScrambler, which are dedicated peripherals to change the format of data

in between memory and the peripheral. The RX channel is dedicated to peripheral-to-memory transfers, and the TX channel is dedicated to memory-to-peripheral transfers. The BitScrambler is capable of performing the aforementioned operations, but as a flexible programmable state machine, it is capable of more advanced things as well.

Feature List

- one BitScrambler, one channel for RX (peripheral-to-memory), one channel for TX (memory-to-peripheral). The two channels support only half-duplex communications, and cannot work at the same time
- support for memory-to-memory transfers
- process up to 32 bits per DMA clock period
- data path controlled by a BitScrambler program stored in the instruction memory
- input registers able to read 0, 8, 16, or 32 bits per clock cycle
- output registers:
 - able to write 0, 8, 16, or 32 bits per clock cycle
 - data sources for output register bits: 64 bits of input data, two counters, LUT RAM data, data output of last cycle, comparators
 - with some restrictions, each of the 32 output register bits can come from any bit on the data sources
- 8 x 257-bit instruction memory, for storing eight instructions, controlling control flow and the data path
- 2048 bytes of lookup table (LUT) memory, configurable as various word widths

For more details, see [ESP32-C5 Technical Reference Manual](#) > Chapter *BitScrambler*.

Pin Assignment

The BitScrambler does not directly interact with IOs, so it has no pins assigned.

4.2.1.13 SDIO Slave Controller

The SDIO Slave controller in ESP32-C5 provides hardware support for the Secure Digital Input/Output (SDIO) device interface. It allows an SDIO host to access ESP32-C5 via an SDIO bus protocol.

Feature List

- compatible with SDIO Physical Layer Specification V2.00 and SDIO Specifications V2.00
- support SPI, 1-bit SDIO, and 4-bit SDIO transfer modes
- clock range of 0 ~ 50 MHz
- configurable sample and drive clock edge
- integrated and SDIO-accessible registers for information interaction
- support SDIO interrupts

- automatic padding data and discarding the padded data on the SDIO bus
- block size up to 512 bytes
- interrupt vector between the host and slave for bidirectional interrupt
- support DMA for data transfer
- support wake-up from sleep when connection is retained

For more details about the SDIO Slave controller, refer to the [ESP32-C5 Technical Reference Manual](#) > Chapter *SDIO Slave Controller (SDIO)*.

Pin Assignment

For details, see Section [2.3.5 Peripheral Pin Assignment](#).

Note:

This peripheral is not supported by chip revision v0.0 and v0.1.

4.2.2 Analog Signal Processing

This subsection describes components on the chip that sense and process real-world data.

4.2.2.1 Temperature Sensor

ESP32-C5 provides a temperature sensor to monitor temperature changes inside the chip in real time. The sensor converts analog voltage to digital values and supports compensation for the temperature offset.

Feature List

- software-triggered temperature measurement. Once triggered, the sensor continuously measures temperature. Software can read the data any time.
- hardware-triggered automatic temperature monitoring
- two modes for automatic monitoring of temperature and support for triggering interrupts
- configurable temperature offset based on the application scenario for improved accuracy
- configurable temperature measurement range
- support for several Event Task Matrix (ETM) related events and tasks

For more details, see [ESP32-C5 Technical Reference Manual](#) > Chapter *Temperature Sensor*.

4.2.2.2 ADC Controller

ESP32-C5 integrates One 12-bit successive approximation ADC (SAR ADC) for measuring analog signals from up to six channels.

Feature List

- 12-bit resolution

- analog inputs sampling from up to six pins
- one-shot sampling mode and multi-channel sampling mode
- multi-channel sampling mode supports:
 - configurable channel sampling sequence
 - two filters whose filter coefficients are configurable
 - two threshold monitors that can trigger an interrupt when the filtered value is below a low threshold or above a high threshold
 - continuous transfer of converted data to memory via GDMA interface
- support for several Event Task Matrix (ETM) related events and tasks

For more details, see [ESP32-C5 Technical Reference Manual](#) > Chapter *ADC Controller*.

Pin Assignment

For details, see Section [2.3.5 Peripheral Pin Assignment](#).

4.2.2.3 Analog Voltage Comparator

ESP32-C5 provides an analog voltage comparator which contains two special pads. This peripheral can be used to compare the voltages of the two pads or compare the voltage of one pad with a stable internal voltage that is adjustable.

Feature List

- internal or external reference voltage
- supported internal reference voltage ranging from 0 to $0.7 * VDD_PST$
- support for ETM
- interrupt triggered when the measured voltage reaches the reference voltage

For more details, see [ESP32-C5 Technical Reference Manual](#) > Chapter *Analog Voltage Comparator*.

Pin Assignment

For details, see Section [2.3.5 Peripheral Pin Assignment](#).

4.3 Wireless Communication

This section describes the chip's wireless communication capabilities, spanning radio technology, Wi-Fi, and Bluetooth.

4.3.1 Radio

This subsection describes the fundamental radio technology embedded in the chip that facilitates wireless communication and data exchange.

4.3.1.1 2.4 & 5 GHz Receiver

The 2.4 & 5 GHz receiver demodulates the 2.4 & 5 GHz RF signal to quadrature baseband signals and converts them to the digital domain with two high-resolution, high-speed ADCs. To adapt to varying signal channel conditions, ESP32-C5 integrates RF filters, Automatic Gain Control (AGC), DC offset cancelation circuits, and baseband filters.

4.3.1.2 2.4 & 5 GHz Transmitter

The 2.4 & 5 GHz transmitter modulates the quadrature baseband signals to the 2.4 & 5 GHz RF signal, and drives the antenna with a high-powered CMOS power amplifier. The use of digital calibration further improves the linearity of the power amplifier.

Additional calibrations are integrated to cancel any radio imperfections, such as:

- carrier leakage
- I/Q amplitude/phase matching
- baseband nonlinearities
- RF nonlinearities
- antenna matching

These built-in calibration routines reduce the cost, time, and specialized equipment required for product testing.

4.3.1.3 Clock Generator

The clock generator produces quadrature clock signals of 2.4 & 5 GHz for both the receiver and the transmitter. All components of the clock generator are integrated into the chip, including inductors, varactors, filters, regulators and dividers.

The clock generator has built-in calibration and self-test circuits. Quadrature clock phases and phase noise are optimized on chip with patented calibration algorithms which ensure the best performance of the receiver and the transmitter.

4.3.2 Wi-Fi

This subsection describes the chip's Wi-Fi capabilities, which facilitate wireless communication at a high data rate.

4.3.2.1 Wi-Fi Radio and Baseband

The ESP32-C5 Wi-Fi radio and baseband support the following features:

- compliant with IEEE 802.11a/b/g/n/ac/ax
- 1T1R in 2.4 GHz and 5 GHz dual band
- 802.11ax
 - 20 MHz-only non-AP mode
 - MCS0 ~ MCS9 in 2.4 GHz band
 - MCS0 ~ MCS7 in 5 GHz band
 - uplink and downlink OFDMA
 - downlink MU-MIMO (multi-user, multiple input, multiple output)
 - longer OFDM symbol, with 0.8, 1.6, and 3.2 μ s guard interval
 - DCM (dual carrier modulation), up to 16-QAM
 - single-user/multi-user beamformee
 - channel quality indication (CQI)
 - RX STBC (single spatial stream)
- 802.11ac
 - MCS0 ~ MCS7 that support 20 MHz bandwidth
 - downlink fullband MU-MIMO (multi-user, multiple input, multiple output)
 - single-user/multi-user beamformee
 - RX STBC (single spatial stream)
 - 0.4 μ s guard interval
- 802.11a/b/g/n
 - MCS0 ~ MCS7 that support 20 MHz and 40 MHz bandwidth
 - MCS32
 - data rate up to 150 Mbps
 - 0.4 μ s guard interval
- adjustable transmitting power
- antenna diversity

ESP32-C5 supports antenna diversity with an external RF switch. This switch is controlled by one or more GPIOs, and used to select the best antenna to minimize the effects of channel imperfections.

4.3.2.2 Wi-Fi MAC

ESP32-C5 implements the full IEEE 802.11a/b/g/n/ac/ax Wi-Fi MAC protocol. It supports the Basic Service Set (BSS) STA and SoftAP operations under the Enhanced Distributed Channel Access (EDCA). Power management is handled automatically with minimal host interaction to minimize the active duty period.

The ESP32-C5 Wi-Fi MAC applies the following low-level protocol functions automatically:

- four virtual Wi-Fi interfaces
- infrastructure BSS in Station mode, SoftAP mode, Station + SoftAP mode, and promiscuous mode
- RTS protection, CTS-to-Self protection, immediate block ACK
- fragmentation and defragmentation
- TX/RX A-MPDU, TX/RX A-MSDU
- transmission opportunity (TXOP)
- Wi-Fi multimedia (WMM)
- GCMP, CCMP, TKIP, WAPI, WEP, BIP, WPA2-PSK, and WPA3-PSK
- automatic beacon monitoring (hardware TSF)
- 802.11mc FTM
- 802.11ax supports:
 - target wake time (TWT) requester
 - multiple BSSIDs
 - triggered response scheduling
 - Multi-User Request-to-Send (MU-RTS), Multi-User Block ACK Request (MU-BAR), and Multi-STA Block ACK (M-BA) frame
 - intra-PPDU power saving mechanism
 - two network allocation vectors (NAV)
 - BSS coloring
 - spatial reuse
 - uplink power headroom
 - operating mode control
 - buffer status report
 - TXOP duration RTS threshold
 - UL-OFDMA random access (UORA)

4.3.2.3 Networking Features

Espressif provides libraries for TCP/IP networking, ESP-WIFI-MESH networking, and other networking protocols over Wi-Fi. TLS 1.0, 1.1, and 1.2 are also supported.

4.3.3 Bluetooth LE

This subsection describes the chip's Bluetooth capabilities, which facilitate wireless communication for low-power, short-range applications.

4.3.3.1 Bluetooth LE PHY

Bluetooth Low Energy PHY in ESP32-C5 supports:

- 1 Mbps PHY
- 2 Mbps PHY for higher data rates
- coded PHY for longer range (125 Kbps and 500 Kbps)
- HW listen before talk (LBT)

4.3.3.2 Bluetooth LE Link Controller

Bluetooth Low Energy Link Controller and Host in ESP32-C5 support:

- direction finding (AoA/AoD)
- periodic advertising with responses (PAWR)
- LE connection subrating (LE enhanced connection update)
- LE advertising extensions and multiple advertising sets
- allow devices to operate in Broadcaster, Observer, Central, and Peripheral roles concurrently
- adaptive frequency hopping and channel assessment
- LE channel selection algorithm #2
- LE power control
- advertising coding selection
- encrypted advertising data
- LE GATT security levels characteristic
- AdvDataInfo in periodic advertising
- LE channel classification
- enhanced attribute protocol
- advertising channel index
- GATT caching
- periodic advertising sync transfer
- high duty cycle non-connectable advertising
- LE data packet length extension
- LE secure connections
- LE privacy 1.2

- link layer extended scanner filter policies
- low duty cycle directed advertising
- link layer encryption
- LE ping

4.3.4 802.15.4

This subsection describes the chip's compatibility with the 802.15.4 standard, which facilitates wireless communication for low-power, short-range applications.

4.3.4.1 802.15.4 PHY

ESP32-C5's 802.15.4 PHY supports:

- O-QPSK PHY in 2.4 GHz
- 250 Kbps data rate
- RSSI and LQI supported

4.3.4.2 802.15.4 MAC

ESP32-C5 supports most key features defined in [IEEE Standard 802.15.4-2015](#), including:

- CSMA/CA
- active scan and energy detect
- HW frame filter
- HW auto acknowledge
- HW auto frame pending
- coordinated sampled listening (CSL)

5 Electrical Characteristics

5.1 Absolute Maximum Ratings

Stresses above those listed in Table 5-1 *Absolute Maximum Ratings* may cause permanent damage to the device. These are stress ratings only and normal operation of the device at these or any other conditions beyond those indicated in Section 5.2 *Recommended Power Supply Characteristics* is not implied. Exposure to absolute-maximum-rated conditions for extended periods may affect device reliability.

Table 5-1. Absolute Maximum Ratings

Parameter	Description	Min	Max	Unit
Input power pins ¹	Allowed input voltage	-0.3	3.6	V
T_{STORE}	Storage temperature	-40	150	°C

¹ For more information on input power pins, see Section 2.5.1 *Power Pins*.

5.2 Recommended Power Supply Characteristics

Table 5-2. Recommended Power Characteristics

Parameter ¹	Description	Min	Typ	Max	Unit
VDDA1, VDDA2, VDDA3, VDDA4, VDDA5, VDDA6, VDDA7, VDDA8	Recommended input voltage	3.0	3.3	3.6	V
VDDPST1, VDDPST3	Recommended input voltage	3.0	3.3	3.6	V
VDD_SPI (as input)	—	3.0	3.3	3.6	V
VDDPST2 ^{2, 3}	Recommended input voltage	3.0	3.3	3.6	V
I_{VDD}	Cumulative input current	0.6	—	—	A

¹ See in conjunction with Section 2.5 *Power Supply*.

² If VDDPST2 is used to power VDD_SPI (see Section 2.5.2 *Power Scheme*), the voltage drop on R_{SPI} should be accounted for.

³ If writing to eFuses, the voltage on VDDPST2 should not exceed 3.3 V as the circuits responsible for burning eFuses are sensitive to higher voltages.

5.3 VDD_SPI Output Characteristics

Table 5-3. VDD_SPI Internal and Output Characteristics

Parameter	Description ¹	Typ	Unit
R_{SPI}	VDD_SPI powered by VDDPST2 via R_{SPI} for 3.3 V flash or PSRAM ²	3	Ω

¹ See in conjunction with Section 2.5.2 Power Scheme.

² VDDPST2 must be more than $VDD_flash_min + I_flash_max * R_{SPI}$;

where

- VDD_flash_min – minimum operating voltage of flash
- I_flash_max – maximum operating current of flash

5.4 DC Characteristics (3.3 V, 25 °C)

Table 5-4. DC Characteristics (3.3 V, 25 °C)

Parameter	Description	Min	Typ	Max	Unit
C_{IN}	Pin capacitance	—	2	—	pF
V_{IH}	High-level input voltage	$0.75 \times VDD^1$	—	$VDD^1 + 0.3$	V
V_{IL}	Low-level input voltage	-0.3	—	$0.25 \times VDD^1$	V
I_{IH}	High-level input current	—	—	50	nA
I_{IL}	Low-level input current	—	—	50	nA
V_{OH}^2	High-level output voltage	$0.8 \times VDD^1$	—	—	V
V_{OL}^2	Low-level output voltage	—	—	$0.1 \times VDD^1$	V
I_{OH}	High-level source current ($VDD^1 = 3.3$ V, $V_{OH} \geq 2.64$ V, PAD_DRIVER = 3)	—	40	—	mA
I_{OL}	Low-level sink current ($VDD^1 = 3.3$ V, $V_{OL} = 0.495$ V, PAD_DRIVER = 3)	—	28	—	mA
R_{PU}	Internal weak pull-up resistor	—	45	—	k Ω
R_{PD}	Internal weak pull-down resistor	—	45	—	k Ω
V_{IH_nRST}	Chip reset release voltage (CHIP_PU voltage is within the specified range)	$0.75 \times VDD^1$	—	$VDD^1 + 0.3$	V
V_{IL_nRST}	Chip reset voltage (CHIP_PU voltage is within the specified range)	-0.3	—	$0.25 \times VDD^1$	V

¹ VDD – voltage from a power pin of a respective power domain.

² V_{OH} and V_{OL} are measured using high-impedance load.

5.5 ADC Characteristics

The measurements in this section are taken with an external 100 nF capacitor connected to the ADC, using DC signals as input, and at an ambient temperature of 25 °C with disabled Wi-Fi.

Table 5-5. ADC Characteristics

Symbol	Min	Max	Unit
DNL (Differential nonlinearity) ¹	-5	5	LSB
INL (Integral nonlinearity)	-5	5	LSB
Sampling rate	—	2000	kSPS ²

¹ To get better DNL results, you can sample multiple times and apply a filter, or calculate the average value.

² kSPS means kilo samples-per-second.

The calibrated ADC results after hardware calibration and [software calibration](#) are shown in Table 5-6. For higher accuracy, you may implement your own calibration methods.

Table 5-6. ADC Calibration Results

Parameter	Description	Min	Max	Unit
Total error	ATTEN0, effective measurement range of 0 ~ 1000	-10	10	mV
	ATTEN1, effective measurement range of 0 ~ 1300	-10	10	mV
	ATTEN2, effective measurement range of 0 ~ 1900	-12	12	mV
	ATTEN3, effective measurement range of 0 ~ 3300	-15	15	mV

5.6 Current Consumption

5.6.1 RF Current Consumption in Active Mode

The current consumption measurements are taken with a 3.3 V supply at 25 °C ambient temperature.

TX current consumption is rated at a 100% duty cycle.

RX current consumption is rated when the peripherals are disabled and the CPU idle.

Table 5-7. Current Consumption for Wi-Fi (2.4 GHz) in Active Mode

Work Mode	RF Condition	Description	Peak (mA)
Active (RF working)	TX	802.11b, 1 Mbps, DSSS @ 20dBm	339
		802.11g, 54 Mbps, OFDM @ 17dBm	270
		802.11n, HT20, MCS7 @ 17dBm	271
		802.11n, HT40, MCS7 @ 16dBm	259
		802.11ax, MCS9 @ 15dBm	246
	RX	802.11b/g/n, HT20	99
		802.11n, HT40	107
		802.11ax, HE20	100

Table 5-8. Current Consumption for Wi-Fi (5 GHz) in Active Mode

Work Mode	RF Condition	Description	Peak (mA)
Active (RF working)	TX	802.11a, 6 Mbps, OFDM @ 17dBm	381
		802.11n, HT20, MCS7 @ 15dBm	377
		802.11n, HT40, MCS7 @ 15dBm	380
		802.11ac, VHT20, MCS7 @ 15dBm	377
		802.11ax, HE20, MCS7 @ 15dBm	377
	RX	802.11a/n, HT20	130
		802.11n, HT40	135
		802.11ac, VHT20	127
802.11ax, HE20		130	

Table 5-9. Current Consumption for Bluetooth LE in Active Mode

Work Mode	RF Condition	Description	Peak (mA)
Active (RF working)	TX	Bluetooth LE @ 20dBm	338
		Bluetooth LE @ 8dBm	195
		Bluetooth LE @ 0dBm	181
		Bluetooth LE @ -15dBm	109
	RX	Bluetooth LE	89

Table 5-10. Current Consumption for 802.15.4 in Active Mode

Work Mode	RF Condition	Description	Peak (mA)
Active (RF working)	TX	802.15.4 @ 20dBm	325
		802.15.4 @ 8dBm	192
		802.15.4 @ 0dBm	180
		802.15.4 @ -15dBm	111
	RX	802.15.4	93

5.6.2 Current Consumption in Other Modes

Table 5-11. Current Consumption in Modem-sleep Mode

Mode	CPU Frequency (MHz)	Description	Typ (mA)	
			All Peripherals Clocks Disabled	All Peripherals Clocks Enabled ¹
Modem-sleep ^{2,3}	240	WAITI	18	27
		CPU while loop	26	35
		Run CoreMark	34	43
	160	WAITI	15	27
		CPU while loop	20	32
		Run CoreMark	26	37
	80	WAITI	12	24
		CPU while loop	15	26
		Run CoreMark	18	29
	40	WAITI	8	18
		CPU while loop	10	19
		Run CoreMark	12	21

¹ In practice, the current consumption might be different depending on which peripherals are enabled.

² In Modem-sleep mode, Wi-Fi is clock gated.

³ In Modem-sleep mode, the consumption might be higher when accessing flash.

Table 5-12. Current Consumption in Low-Power Modes

Mode	Description	Typ (mA)
Light-sleep	CPU and wireless communication modules are powered down, peripheral clocks are disabled, and all GPIOs are high-impedance	0.25
	CPU, wireless communication modules and peripherals are powered down, and all GPIOs are high-impedance	0.06
Deep-sleep	RTC timer and LP memory are powered on	0.012
Power off	CHIP_PU is set to low level, the chip is powered off	0.002

5.7 Memory Specifications

The data below is sourced from the memory vendor datasheet. These values are guaranteed through design and/or characterization but are not fully tested in production. Devices are shipped with the memory erased.

Table 5-13. Flash Specifications

Parameter	Description	Min	Typ	Max	Unit
VCC	Power supply voltage (1.8 V)	1.65	1.80	2.00	V
	Power supply voltage (3.3 V)	2.7	3.3	3.6	V

Cont'd on next page

Table 5-13 – cont'd from previous page

Parameter	Description	Min	Typ	Max	Unit
F_C	Maximum clock frequency	80	—	—	MHz
—	Program/erase cycles	100,000	—	—	cycles
T_{RET}	Data retention time	20	—	—	years
T_{PP}	Page program time	—	0.8	5	ms
T_{SE}	Sector erase time (4 KB)	—	70	500	ms
T_{BE1}	Block erase time (32 KB)	—	0.2	2	s
T_{BE2}	Block erase time (64 KB)	—	0.3	3	s
T_{CE}	Chip erase time (16 Mb)	—	7	20	s
	Chip erase time (32 Mb)	—	20	60	s
	Chip erase time (64 Mb)	—	25	100	s
	Chip erase time (128 Mb)	—	60	200	s
	Chip erase time (256 Mb)	—	70	300	s

Table 5-14. PSRAM Specifications

Parameter	Description	Min	Typ	Max	Unit
VCC	Power supply voltage (1.8 V)	1.62	1.80	1.98	V
	Power supply voltage (3.3 V)	2.7	3.3	3.6	V
F_C	Maximum clock frequency	80	—	—	MHz

5.8 Reliability

Table 5-15. Reliability Qualifications

Test Item	Test Conditions	Test Standard
HTOL (High Temperature Operating Life)	125 °C, 1000 hours, 3.6 V ¹	JESD22-A108
ESD (Electro-Static Discharge Sensitivity)	HBM (Human Body Mode) ² ± 2000 V	JS-001
	CDM (Charge Device Mode) ³ ± 1000 V	JS-002
Latch up	Current trigger ± 200 mA	JESD78
	Voltage trigger 1.5 × VDD _{max}	
Preconditioning	Bake 24 hours @125 °C Moisture soak (level 3: 192 hours @30 °C, 60% RH) IR reflow solder: 260 + 0 °C, 20 seconds, three times	J-STD-020, JESD47, JESD22-A113
TCT (Temperature Cycling Test)	–65 °C / 150 °C, 500 cycles	JESD22-A104
uHAST (Highly Accelerated Stress Test, unbiased)	130 °C, 85% RH, 96 hours	JESD22-A118
HTSL (High Temperature Storage Life)	150 °C, 1000 hours	JESD22-A103

Cont'd on next page

Table 5-15 – cont'd from previous page

Test Item	Test Conditions	Test Standard
LTSL (Low Temperature Storage Life)	–40 °C, 1000 hours	JESD22-A119

¹ 5G RF underwent a separate HTOL test under the conditions: 105°C, 1700 hours, 3.45 V.

² JEDEC document JEP155 states that 500 V HBM allows safe manufacturing with a standard ESD control process.

³ JEDEC document JEP157 states that 250 V CDM allows safe manufacturing with a standard ESD control process.

6 RF Characteristics

This section contains tables with RF characteristics of the Espressif product.

The RF data is measured at the antenna port, where RF cable is connected, including the front-end loss. The front-end circuit is a 0 Ω resistor.

Devices should operate in the center frequency range allocated by regional regulatory authorities. The target center frequency range and the target transmit power are configurable by software. See [ESP RF Test Tool and Test Guide](#) for instructions.

Unless otherwise stated, the RF tests are conducted with a 3.3 V ($\pm 5\%$) supply at 25 °C ambient temperature.

6.1 2.4 GHz Wi-Fi Radio

Table 6-1. 2.4 GHz Wi-Fi RF Characteristics

Name	Description
Center frequency range of operating channel	2412 ~ 2484 MHz
Wi-Fi wireless standard	IEEE 802.11b/g/n/ax

6.1.1 2.4 GHz Wi-Fi RF Transmitter (TX) Characteristics

Table 6-2. 2.4 GHz TX Power with Spectral Mask and EVM Meeting 802.11 Standards

Rate	Min (dBm)	Typ (dBm)	Max (dBm)
802.11b, 1 Mbps, DSSS	—	20.0	—
802.11b, 11 Mbps, CCK	—	20.0	—
802.11g, 6 Mbps, OFDM	—	19.0	—
802.11g, 54 Mbps, OFDM	—	17.0	—
802.11n, HT20, MCS0	—	19.0	—
802.11n, HT20, MCS7	—	17.0	—
802.11n, HT40, MCS0	—	18.0	—
802.11n, HT40, MCS7	—	16.0	—
802.11ax, HE20, MCS0	—	19.0	—
802.11ax, HE20, MCS9	—	15.0	—

Table 6-3. 2.4 GHz TX EVM Test¹

Rate	Min (dB)	Typ (dB)	Limit (dB)
802.11b, 1 Mbps, DSSS	—	-25.0	-10.0
802.11b, 11 Mbps, CCK	—	-25.0	-10.0

Cont'd on next page

Table 6-3 – cont'd from previous page

Rate	Min (dB)	Typ (dB)	Limit (dB)
802.11g, 6 Mbps, OFDM	—	-25.0	-5.0
802.11g, 54 Mbps, OFDM	—	-30.0	-25.0
802.11n, HT20, MCS0	—	-25.0	-5.0
802.11n, HT20, MCS7	—	-31.5	-27.0
802.11n, HT40, MCS0	—	-25.0	-5.0
802.11n, HT40, MCS7	—	-32.0	-27.0
802.11ax, HE20, MCS0	—	-25.0	-5.0
802.11ax, HE20, MCS9	—	-34.5	-32.0

¹ EVM is measured at the corresponding typical TX power provided in Table 6-2 *2.4 GHz TX Power with Spectral Mask and EVM Meeting 802.11 Standards* above.

6.1.2 2.4 GHz Wi-Fi RF Receiver (RX) Characteristics

For RX tests, the PER (packet error rate) limit is 8% for 802.11b, and 10% for 802.11g/n/ax.

Table 6-4. 2.4 GHz RX Sensitivity

Rate	Min (dBm)	Typ (dBm)	Max (dBm)
802.11b, 1 Mbps, DSSS	—	-101.0	—
802.11b, 2 Mbps, DSSS	—	-98.0	—
802.11b, 5.5 Mbps, CCK	—	-95.0	—
802.11b, 11 Mbps, CCK	—	-91.0	—
802.11g, 6 Mbps, OFDM	—	-96.0	—
802.11g, 9 Mbps, OFDM	—	-94.0	—
802.11g, 12 Mbps, OFDM	—	-93.0	—
802.11g, 18 Mbps, OFDM	—	-91.0	—
802.11g, 24 Mbps, OFDM	—	-88.0	—
802.11g, 36 Mbps, OFDM	—	-85.0	—
802.11g, 48 Mbps, OFDM	—	-81.0	—
802.11g, 54 Mbps, OFDM	—	-79.0	—
802.11n, HT20, MCS0	—	-95.5	—
802.11n, HT20, MCS1	—	-94.0	—
802.11n, HT20, MCS2	—	-91.0	—
802.11n, HT20, MCS3	—	-88.0	—
802.11n, HT20, MCS4	—	-84.5	—
802.11n, HT20, MCS5	—	-80.0	—
802.11n, HT20, MCS6	—	-78.0	—
802.11n, HT20, MCS7	—	-77.0	—
802.11n, HT40, MCS0	—	-93.0	—
802.11n, HT40, MCS1	—	-91.0	—

Cont'd on next page

Table 6-4 – cont'd from previous page

Rate	Min (dBm)	Typ (dBm)	Max (dBm)
802.11n, HT40, MCS2	—	-88.0	—
802.11n, HT40, MCS3	—	-84.0	—
802.11n, HT40, MCS4	—	-82.0	—
802.11n, HT40, MCS5	—	-77.0	—
802.11n, HT40, MCS6	—	-75.0	—
802.11n, HT40, MCS7	—	-74.0	—
802.11ax, HE20, MCS0	—	-95.5	—
802.11ax, HE20, MCS1	—	-92.5	—
802.11ax, HE20, MCS2	—	-90.0	—
802.11ax, HE20, MCS3	—	-87.0	—
802.11ax, HE20, MCS4	—	-84.0	—
802.11ax, HE20, MCS5	—	-80.0	—
802.11ax, HE20, MCS6	—	-78.5	—
802.11ax, HE20, MCS7	—	-76.5	—
802.11ax, HE20, MCS8	—	-72.5	—
802.11ax, HE20, MCS9	—	-70.5	—

Table 6-5. 2.4 GHz Maximum RX Level

Rate	Min (dBm)	Typ (dBm)	Max (dBm)
802.11b, 1 Mbps, DSSS	—	5	—
802.11b, 11 Mbps, CCK	—	5	—
802.11g, 6 Mbps, OFDM	—	5	—
802.11g, 54 Mbps, OFDM	—	0	—
802.11n, HT20, MCS0	—	5	—
802.11n, HT20, MCS7	—	0	—
802.11n, HT40, MCS0	—	5	—
802.11n, HT40, MCS7	—	0	—
802.11ax, HE20, MCS0	—	5	—
802.11ax, HE20, MCS9	—	0	—

Table 6-6. 2.4 GHz RX Adjacent Channel Rejection

Rate	Min (dB)	Typ (dB)	Max (dB)
802.11b, 1 Mbps, DSSS	—	41	—
802.11b, 11 Mbps, CCK	—	40	—
802.11g, 6 Mbps, OFDM	—	37	—
802.11g, 54 Mbps, OFDM	—	17	—

Cont'd on next page

Table 6-6 – cont'd from previous page

Rate	Min (dB)	Typ (dB)	Max (dB)
802.11n, HT20, MCS0	—	34	—
802.11n, HT20, MCS7	—	16	—
802.11n, HT40, MCS0	—	24	—
802.11n, HT40, MCS7	—	13	—
802.11ax, HE20, MCS0	—	38	—
802.11ax, HE20, MCS9	—	12	—

6.2 5 GHz Wi-Fi Radio

Table 6-7. 5 GHz Wi-Fi RF Characteristics

Name	Description
Center frequency range of operating channel	5180 ~ 5885 MHz
Wi-Fi wireless standard	IEEE 802.11a/n/ac/ax

6.2.1 5 GHz Wi-Fi RF Transmitter (TX) Characteristics

Table 6-8. 5 GHz TX Power with Spectral Mask and EVM Meeting 802.11 Standards

Rate	Min (dBm)	Typ (dBm)	Max (dBm)
802.11a, 6 Mbps, OFDM	—	19.0	—
802.11a, 54 Mbps, OFDM	—	17.0	—
802.11n, HT20, MCS0	—	19.0	—
802.11n, HT20, MCS7	—	16.0	—
802.11n, HT40, MCS0	—	18.0	—
802.11n, HT40, MCS7	—	15.0	—
802.11ac, VHT20, MCS0	—	19.0	—
802.11ac, VHT20, MCS7	—	16.0	—
802.11ax, HE20, MCS0	—	19.0	—
802.11ax, HE20, MCS7	—	16.0	—

Table 6-9. 5 GHz TX EVM Test¹

Rate	Min (dB)	Typ (dB)	Limit (dB)
802.11a, 6 Mbps, OFDM	—	-25.0	-5.0
802.11a, 54 Mbps, OFDM	—	-29.0	-25.0
802.11n, HT20, MCS0	—	-25.0	-5.0
802.11n, HT20, MCS7	—	-31.0	-27.0

Cont'd on next page

Table 6-9 – cont'd from previous page

Rate	Min (dB)	Typ (dB)	Limit (dB)
802.11n, HT40, MCS0	—	-25.0	-5.0
802.11n, HT40, MCS7	—	-31.0	-27.0
802.11ac, VHT20, MCS0	—	-25.0	-5.0
802.11ac, VHT20, MCS7	—	-31.0	-27.0
802.11ax, HE20, MCS0	—	-25.0	-5.0
802.11ax, HE20, MCS7	—	-31.5	-27.0

¹ EVM is measured at the corresponding typical TX power provided in Table 6-8 *5 GHz TX Power with Spectral Mask and EVM Meeting 802.11 Standards* above.

6.2.2 5 GHz Wi-Fi RF Receiver (RX) Characteristics

For RX tests, the PER (packet error rate) limit is 10% for 802.11a/n/ac/ax.

Table 6-10. 5 GHz RX Sensitivity

Rate	Min (dBm)	Typ (dBm)	Max (dBm)
802.11a, 6 Mbps, OFDM	—	-95.0	—
802.11a, 9 Mbps, OFDM	—	-93.5	—
802.11a, 12 Mbps, OFDM	—	-92.0	—
802.11a, 18 Mbps, OFDM	—	-90.0	—
802.11a, 24 Mbps, OFDM	—	-87.0	—
802.11a, 36 Mbps, OFDM	—	-84.0	—
802.11a, 48 Mbps, OFDM	—	-79.0	—
802.11a, 54 Mbps, OFDM	—	-77.0	—
802.11n, HT20, MCS0	—	-94.5	—
802.11n, HT20, MCS1	—	-93.0	—
802.11n, HT20, MCS2	—	-90.0	—
802.11n, HT20, MCS3	—	-87.0	—
802.11n, HT20, MCS4	—	-83.0	—
802.11n, HT20, MCS5	—	-79.0	—
802.11n, HT20, MCS6	—	-77.5	—
802.11n, HT20, MCS7	—	-76.0	—
802.11n, HT40, MCS0	—	-92.0	—
802.11n, HT40, MCS1	—	-90.0	—
802.11n, HT40, MCS2	—	-87.0	—
802.11n, HT40, MCS3	—	-84.0	—
802.11n, HT40, MCS4	—	-81.0	—
802.11n, HT40, MCS5	—	-76.0	—
802.11n, HT40, MCS6	—	-74.0	—
802.11n, HT40, MCS7	—	-73.0	—

Cont'd on next page

Table 6-10 – cont'd from previous page

Rate	Min (dBm)	Typ (dBm)	Max (dBm)
802.11ac, VHT20, MCS0	—	-95.0	—
802.11ac, VHT20, MCS1	—	-93.0	—
802.11ac, VHT20, MCS2	—	-90.0	—
802.11ac, VHT20, MCS3	—	-87.0	—
802.11ac, VHT20, MCS4	—	-83.5	—
802.11ac, VHT20, MCS5	—	-79.0	—
802.11ac, VHT20, MCS6	—	-77.5	—
802.11ac, VHT20, MCS7	—	-76.0	—
802.11ax, HE20, MCS0	—	-94.5	—
802.11ax, HE20, MCS1	—	-91.5	—
802.11ax, HE20, MCS2	—	-88.5	—
802.11ax, HE20, MCS3	—	-86.0	—
802.11ax, HE20, MCS4	—	-82.5	—
802.11ax, HE20, MCS5	—	-79.0	—
802.11ax, HE20, MCS6	—	-77.5	—
802.11ax, HE20, MCS7	—	-75.0	—

Table 6-11. 5 GHz Maximum RX Level

Rate	Min (dBm)	Typ (dBm)	Max (dBm)
802.11a, 6 Mbps, OFDM	—	5	—
802.11a, 54 Mbps, OFDM	—	0	—
802.11n, HT20, MCS0	—	5	—
802.11n, HT20, MCS7	—	0	—
802.11n, HT40, MCS0	—	5	—
802.11n, HT40, MCS7	—	0	—
802.11ac, VHT20, MCS0	—	5	—
802.11ac, VHT20, MCS7	—	0	—
802.11ax, HE20, MCS0	—	5	—
802.11ax, HE20, MCS7	—	0	—

Table 6-12. 5 GHz RX Adjacent Channel Rejection

Rate	Min (dB)	Typ (dB)	Max (dB)
802.11a, 6 Mbps, OFDM	—	29	—
802.11a, 54 Mbps, OFDM	—	9	—
802.11n, HT20, MCS0	—	26	—
802.11n, HT20, MCS7	—	8	—

Cont'd on next page

Table 6-12 – cont'd from previous page

Rate	Min (dB)	Typ (dB)	Max (dB)
802.11n, HT40, MCS0	—	29	—
802.11n, HT40, MCS7	—	11	—
802.11ac, VHT20, MCS0	—	25	—
802.11ac, VHT20, MCS7	—	6	—
802.11ax, HE20, MCS0	—	25	—
802.11ax, HE20, MCS7	—	6	—

6.3 Bluetooth LE Radio

Table 6-13. Bluetooth LE RF Characteristics

Name	Description
Center frequency range of operating channel	2402 ~ 2480 MHz
RF transmit power range	-15~20 dBm

6.3.1 Bluetooth LE RF Transmitter (TX) Characteristics

Table 6-14. Bluetooth LE - Transmitter Characteristics - 1 Mbps

Parameter	Description	Min	Typ	Max	Unit
Carrier frequency offset and drift	Max. $ f_n _{n=0, 1, 2, 3, \dots, k}$	—	7.0	—	kHz
	Max. $ f_0 - f_n _{n=2, 3, 4, \dots, k}$	—	0.6	—	kHz
	Max. $ f_n - f_{n-5} _{n=6, 7, 8, \dots, k}$	—	0.6	—	kHz
	$ f_1 - f_0 $	—	0.3	—	kHz
Modulation characteristics	$\Delta F1_{avg}$	—	250.0	—	kHz
	Min. $\Delta F2_{max}$ (for at least 99.9% of all $\Delta F2_{max}$)	—	255.0	—	kHz
	$\Delta F2_{avg}/\Delta F1_{avg}$	—	0.98	—	—
In-band emissions	± 2 MHz offset	—	-33	—	dBm
	± 3 MHz offset	—	-40	—	dBm
	$> \pm 3$ MHz offset	—	-45	—	dBm

Table 6-15. Bluetooth LE - Transmitter Characteristics - 2 Mbps

Parameter	Description	Min	Typ	Max	Unit
Carrier frequency offset and drift	Max. $ f_n _{n=0, 1, 2, 3, \dots, k}$	—	7.0	—	kHz
	Max. $ f_0 - f_n _{n=2, 3, 4, \dots, k}$	—	0.6	—	kHz
	Max. $ f_n - f_{n-5} _{n=6, 7, 8, \dots, k}$	—	0.7	—	kHz
	$ f_1 - f_0 $	—	0.3	—	kHz
Modulation characteristics	$\Delta F1_{avg}$	—	495.1	—	kHz

Cont'd on next page

Table 6-15 – cont'd from previous page

Parameter	Description	Min	Typ	Max	Unit
	Min. $\Delta F2_{\max}$ (for at least 99.9% of all $\Delta F2_{\max}$)	—	515.0	—	kHz
	$\Delta F2_{\text{avg}}/\Delta F1_{\text{avg}}$	—	0.99	—	—
In-band emissions	± 4 MHz offset	—	-43	—	dBm
	± 5 MHz offset	—	-45	—	dBm
	$> \pm 5$ MHz offset	—	-45	—	dBm

Table 6-16. Bluetooth LE - Transmitter Characteristics - 125 Kbps

Parameter	Description	Min	Typ	Max	Unit
Carrier frequency offset and drift	Max. $ f_n _{n=0, 1, 2, 3, \dots, k}$	—	7.0	—	kHz
	Max. $ f_0 - f_n _{n=1, 2, 3, \dots, k}$	—	0.3	—	kHz
	$ f_0 - f_3 $	—	0.3	—	kHz
	Max. $ f_n - f_{n-3} _{n=7, 8, 9, \dots, k}$	—	0.4	—	kHz
Modulation characteristics	$\Delta F1_{\text{avg}}$	—	251.2	—	kHz
	Min. $\Delta F1_{\max}$ (for at least 99.9% of all $\Delta F1_{\max}$)	—	256.7	—	kHz
In-band emissions	± 2 MHz offset	—	-31	—	dBm
	± 3 MHz offset	—	-40	—	dBm
	$> \pm 3$ MHz offset	—	-43	—	dBm

Table 6-17. Bluetooth LE - Transmitter Characteristics - 500 Kbps

Parameter	Description	Min	Typ	Max	Unit
Carrier frequency offset and drift	Max. $ f_n _{n=0, 1, 2, 3, \dots, k}$	—	7.0	—	kHz
	Max. $ f_0 - f_n _{n=1, 2, 3, \dots, k}$	—	0.5	—	kHz
	$ f_0 - f_3 $	—	0.2	—	kHz
	Max. $ f_n - f_{n-3} _{n=7, 8, 9, \dots, k}$	—	0.5	—	kHz
Modulation characteristics	$\Delta F2_{\text{avg}}$	—	246.3	—	kHz
	Min. $\Delta F2_{\max}$ (for at least 99.9% of all $\Delta F2_{\max}$)	—	253.3	—	kHz
In-band emissions	± 2 MHz offset	—	-31	—	dBm
	± 3 MHz offset	—	-40	—	dBm
	$> \pm 3$ MHz offset	—	-43	—	dBm

6.3.2 Bluetooth LE RF Receiver (RX) Characteristics

Table 6-18. Bluetooth LE - Receiver Characteristics - 1 Mbps

Parameter	Description	Min	Typ	Max	Unit
Sensitivity @30.8% PER	—	—	-99.0	—	dBm
Maximum received signal @30.8% PER	—	—	5	—	dBm

Cont'd on next page

Table 6-18 – cont'd from previous page

Parameter		Description	Min	Typ	Max	Unit
C/I and receiver selectivity performance	Co-channel	$F = F_0$ MHz	—	9	—	dB
	Adjacent channel	$F = F_0 + 1$ MHz	—	-4	—	dB
		$F = F_0 - 1$ MHz	—	-3	—	dB
		$F = F_0 + 2$ MHz	—	-31	—	dB
		$F = F_0 - 2$ MHz	—	-34	—	dB
		$F = F_0 + 3$ MHz	—	-33	—	dB
		$F = F_0 - 3$ MHz	—	-43	—	dB
		$F \geq F_0 + 4$ MHz	—	-37	—	dB
		$F \leq F_0 - 4$ MHz	—	-50	—	dB
	Image frequency	—	—	-28	—	dB
Adjacent channel to image frequency	$F = F_{image} + 1$ MHz	—	-27	—	dB	
	$F = F_{image} - 1$ MHz	—	-30	—	dB	
Out-of-band blocking performance		30 MHz ~ 2000 MHz	—	-13	—	dBm
		2003 MHz ~ 2399 MHz	—	-25	—	dBm
		2484 MHz ~ 2997 MHz	—	-20	—	dBm
		3000 MHz ~ 12.75 GHz	—	-20	—	dBm
Intermodulation		—	—	-41	—	dBm

Table 6-19. Bluetooth LE - Receiver Characteristics - 2 Mbps

Parameter		Description	Min	Typ	Max	Unit
Sensitivity @30.8% PER		—	—	-96.5	—	dBm
Maximum received signal @30.8% PER		—	—	5	—	dBm
C/I and receiver selectivity performance	Co-channel	$F = F_0$ MHz	—	8	—	dB
	Adjacent channel	$F = F_0 + 2$ MHz	—	-8	—	dB
		$F = F_0 - 2$ MHz	—	-10	—	dB
		$F = F_0 + 4$ MHz	—	-27	—	dB
		$F = F_0 - 4$ MHz	—	-42	—	dB
		$F = F_0 + 6$ MHz	—	-39	—	dB
		$F = F_0 - 6$ MHz	—	-50	—	dB
		$F \geq F_0 + 8$ MHz	—	-48	—	dB
		$F \leq F_0 - 8$ MHz	—	-54	—	dB
	Image frequency	—	—	-27	—	dB
Adjacent channel to image frequency	$F = F_{image} + 2$ MHz	—	-26	—	dB	
	$F = F_{image} - 2$ MHz	—	-28	—	dB	
Out-of-band blocking performance		30 MHz ~ 2000 MHz	—	-13	—	dBm
		2003 MHz ~ 2399 MHz	—	-25	—	dBm
		2484 MHz ~ 2997 MHz	—	-20	—	dBm
		3000 MHz ~ 12.75 GHz	—	-20	—	dBm
Intermodulation		—	—	-39	—	dBm

Table 6-20. Bluetooth LE - Receiver Characteristics - 125 Kbps

Parameter	Description	Min	Typ	Max	Unit	
Sensitivity @30.8% PER	—	—	-107.0	—	dBm	
Maximum received signal @30.8% PER	—	—	5	—	dBm	
C/I and receiver selectivity performance	Co-channel	$F = F_0$ MHz	—	3	—	dB
	Adjacent channel	$F = F_0 + 1$ MHz	—	-6	—	dB
		$F = F_0 - 1$ MHz	—	-7	—	dB
		$F = F_0 + 2$ MHz	—	-34	—	dB
		$F = F_0 - 2$ MHz	—	-39	—	dB
		$F = F_0 + 3$ MHz	—	-30	—	dB
		$F = F_0 - 3$ MHz	—	-47	—	dB
		$F \geq F_0 + 4$ MHz	—	-46	—	dB
		$F \leq F_0 - 4$ MHz	—	-54	—	dB
	Image frequency	—	—	-28	—	dB
Adjacent channel to image frequency	$F = F_{image} + 1$ MHz	—	-34	—	dB	
	$F = F_{image} - 1$ MHz	—	-31	—	dB	

Table 6-21. Bluetooth LE - Receiver Characteristics - 500 Kbps

Parameter	Description	Min	Typ	Max	Unit	
Sensitivity @30.8% PER	—	—	-103.5	—	dBm	
Maximum received signal @30.8% PER	—	—	5	—	dBm	
C/I and receiver selectivity performance	Co-channel	$F = F_0$ MHz	—	3	—	dB
	Adjacent channel	$F = F_0 + 1$ MHz	—	-6	—	dB
		$F = F_0 - 1$ MHz	—	-7	—	dB
		$F = F_0 + 2$ MHz	—	-33	—	dB
		$F = F_0 - 2$ MHz	—	-38	—	dB
		$F = F_0 + 3$ MHz	—	-38	—	dB
		$F = F_0 - 3$ MHz	—	-47	—	dB
		$F \geq F_0 + 4$ MHz	—	-41	—	dB
		$F \leq F_0 - 4$ MHz	—	-52	—	dB
	Image frequency	—	—	-23	—	dB
Adjacent channel to image frequency	$F = F_{image} + 1$ MHz	—	-29	—	dB	
	$F = F_{image} - 1$ MHz	—	-29	—	dB	

6.4 802.15.4 Radio

Table 6-22. 802.15.4 RF Characteristics

Name	Description
Center frequency range of operating channel	2405 ~ 2480 MHz

¹ Zigbee in the 2.4 GHz range supports 16 channels at 5 MHz spacing from channel 11 to channel 26.

6.4.1 802.15.4 RF Transmitter (TX) Characteristics

Table 6-23. 802.15.4 Transmitter Characteristics - 250 Kbps

Parameter	Min	Typ	Max	Unit
RF transmit power range	-15.0	—	20.0	dBm
EVM	—	4.0%	—	—

6.4.2 802.15.4 RF Receiver (RX) Characteristics

Table 6-24. 802.15.4 Receiver Characteristics - 250 Kbps

Parameter	Description	Min	Typ	Max	Unit	
Sensitivity @1% PER	—	—	-104.0	—	dBm	
Maximum received signal @1% PER	—	—	5	—	dBm	
Relative jamming level	Adjacent channel	$F = F_0 + 5 \text{ MHz}$	—	28	—	dB
		$F = F_0 - 5 \text{ MHz}$	—	32	—	dB
	Alternate channel	$F = F_0 + 10 \text{ MHz}$	—	48	—	dB
		$F = F_0 - 10 \text{ MHz}$	—	53	—	dB

7 Packaging

- For information about tape, reel, and chip marking, please refer to [ESP32-C5 Chip Packaging Information](#).
- The pins of the chip are numbered in anti-clockwise order starting from Pin 1 in the top view. For pin numbers and pin names, see also Figure 2-1 *ESP32-C5HR2 & ESP32-C5HR8 Pin Layout (Top View)* and Figure 2-2 *ESP32-C5HF4 Pin Layout (Top View)*.
- The recommended land pattern [source file \(asc\)](#) is available for download. You can view the file with [Autodesk Viewer](#).

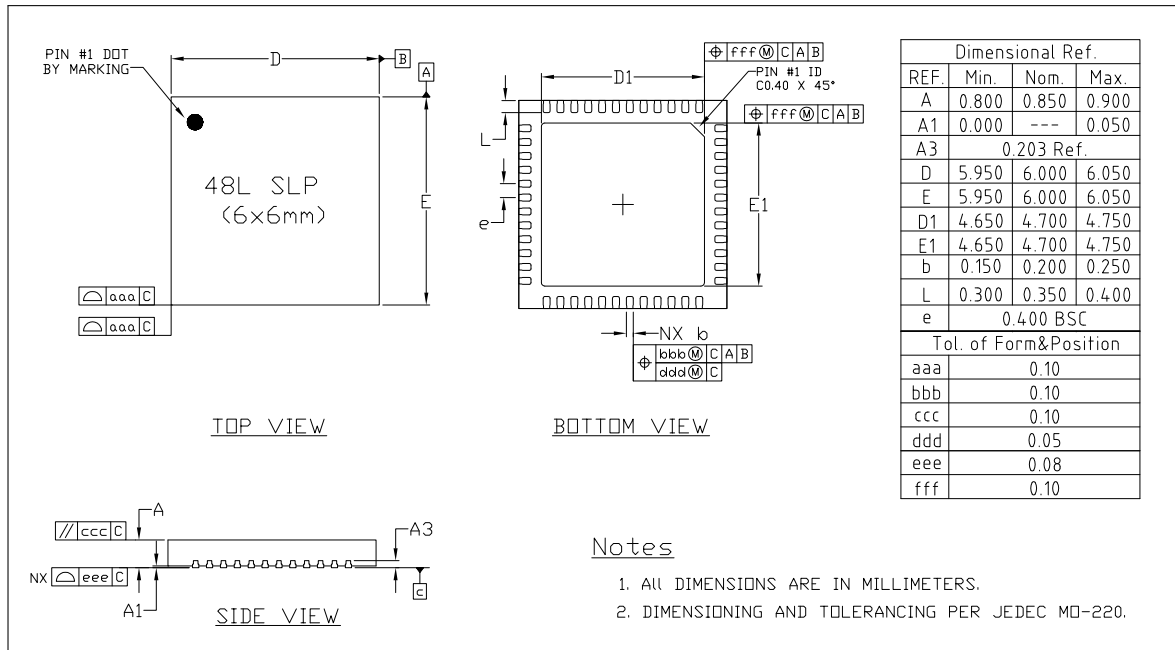

Figure 7-1. QFN48 (6 × 6 mm) Package

ESP32-C5 Consolidated Pin Overview

Table 7-1. Pin Overview

Pin No.	Pin Name	Pin Type	Pin Providing Power	Pin Settings		Analog Function		LP IO MUX Function			IO MUX Function								
				At Reset	After Reset	0	1	0	1	2	0	Type	1	Type	2	Type			
1	VDDA6	Power																	
2	GND	Power																	
3	VDDA7	Power																	
4	XTAL_N	Analog																	
5	XTAL_P	Analog																	
6	VDDA8	Power																	
7	CHIP_PU	Analog	VDDPST1																
8	VDDPST1	Power																	
9	XTAL_32K_P	IO	VDDPST1			XTAL_32K_P		LP_GPIO0	LP_UART_DTRN			GPIO0	I/O/T	GPIO0	I/O/T				
10	XTAL_32K_N	IO	VDDPST1			XTAL_32K_N	ADC1_CHO	LP_GPIO1	LP_UART_DSRN			GPIO1	I/O/T	GPIO1	I/O/T				
11	MTMS	IO	VDDPST1	IE	IE	ADC1_CH1		LP_GPIO2	LP_UART_RTSN	LP_I2C_SDA		MTMS	I	GPIO2	I/O/T	FSPIQ		I/O/T	
12	MTDI	IO	VDDPST1	IE	IE	ADC1_CH2		LP_GPIO3	LP_UART_CTSN	LP_I2C_SCL		MTDI	I	GPIO3	I/O/T				
13	MTCK	IO	VDDPST1		IE, WPU	ADC1_CH3		LP_GPIO4	LP_UART_RXD			MTCK	I	GPIO4	I/O/T	FSPiHD		I/O/T	
14	MTDO	IO	VDDPST1	IE	IE	ADC1_CH4		LP_GPIO5	LP_UART_TXD			MTDO	O/T	GPIO5	I/O/T	FSPiWP		I/O/T	
15	GPIO6	IO	VDDPST1	IE	IE	ADC1_CH5		LP_GPIO6				GPIO6	I/O/T	GPIO6	I/O/T	FSPiCLK		I/O/T	
16	GPIO7	IO	VDDPST1	IE	IE							SDIO_DATA1	I/O/T	GPIO7	I/O/T	FSPiD		I/O/T	
17	GPIO8	IO	VDDPST1		IE	PAD_COMPO						SDIO_DATA0	I/O/T	GPIO8	I/O/T				
18	GPIO9	IO	VDDPST1		IE	PAD_COMP1						SDIO_CLK	I	GPIO9	I/O/T				
19	GPIO10	IO	VDDPST1		IE							SDIO_CMD	I/O/T	GPIO10	I/O/T	FSPiCS0		I/O/T	
20	UOTXD	IO	VDDPST1		WPU							UOTXD	O	GPIO11	I/O/T				
21	UORXD	IO	VDDPST1		IE, WPU							UORXD	I	GPIO12	I/O/T				
22	GPIO13	IO	VDDPST2		IE	USB_D-						SDIO_DATA3	I/O/T	GPIO13	I/O/T				
23	GPIO14	IO	VDDPST2	USB_PU	IE, USB_PU	USB_D+						SDIO_DATA2	I/O/T	GPIO14	I/O/T				
24	VDDPST2	Power																	
25	SPICS1	IO	VDD_SPI	WPU	IE, WPU							SPICS1	O/T	GPIO15	I/O/T				
26	SPICS0/NC	IO	VDD_SPI	WPU	IE, WPU							SPICS0	O/T	GPIO16	I/O/T				
27	SPIQ/NC	IO	VDD_SPI	WPU	IE, WPU							SPIQ	I/O/T	GPIO17	I/O/T				
28	SPiWP/NC	IO	VDD_SPI	WPU	IE, WPU							SPiWP	I/O/T	GPIO18	I/O/T				
29	VDD_SPI/NC	Power/IO	—			VDD_SPI								GPIO19	I/O/T	GPIO19	I/O/T		
30	SPiHD/NC	IO	VDD_SPI	WPU	IE, WPU							SPiHD	I/O/T	GPIO20	I/O/T				
31	SPiCLK/NC	IO	VDD_SPI	WPU	IE, WPU							SPiCLK	O/T	GPIO21	I/O/T				
32	SPiD/NC	IO	VDD_SPI	WPU	IE, WPU							SPiD	I/O/T	GPIO22	I/O/T				
33	GPIO23	IO	VDDPST3		IE							GPIO23	I/O/T	GPIO23	I/O/T				
34	GPIO24	IO	VDDPST3		IE							GPIO24	I/O/T	GPIO24	I/O/T				
35	GPIO25	IO	VDDPST3	IE	IE							GPIO25	I/O/T	GPIO25	I/O/T				
36	GPIO26	IO	VDDPST3	IE	IE							GPIO26	I/O/T	GPIO26	I/O/T				
37	GPIO27	IO	VDDPST3	IE, WPU	IE, WPU							GPIO27	I/O/T	GPIO27	I/O/T				
38	GPIO28	IO	VDDPST3	IE, WPU	IE, WPU							GPIO28	I/O/T	GPIO28	I/O/T				
39	VDDPST3	Power																	
40	VDDA1	Power																	
41	VDDA2	Power																	
42	ANT_2G	Analog																	
43	GND	Power																	
44	VDDA3	Power																	
45	VDDA4	Power																	
46	VDDA5	Power																	
47	GND	Power																	
48	ANT_5G	Analog																	

* For details, see Section 2 Pins. Regarding highlighted cells, see Section 2.3.4 Restrictions for GPIOs and LP GPIOs.

Datasheet Versioning

Datasheet Version	Status	Watermark	Definition
v0.1 ~ v0.5 (excluding v0.5)	Draft	Confidential	This datasheet is under development for products in the design stage. Specifications may change without prior notice.
v0.5 ~ v1.0 (excluding v1.0)	Preliminary release	Preliminary	This datasheet is actively updated for products in the verification stage. Specifications may change before mass production, and the changes will be documented in the datasheet's Revision History.
v1.0 and higher	Official release	—	This datasheet is publicly released for products in mass production. Specifications are finalized, and major changes will be communicated via Product Change Notifications (PCN) .
Any version	—	Not Recommended for New Design (NRND) ¹	This datasheet is updated less frequently for products not recommended for new designs.
Any version	—	End of Life (EOL) ²	This datasheet is no longer maintained for products that have reached end of life.

¹ Watermark will be added to the datasheet title page only when all the product variants covered by this datasheet are not recommended for new designs.

² Watermark will be added to the datasheet title page only when all the product variants covered by this datasheet have reached end of life.

Glossary

module

A self-contained unit integrated within the chip to extend its capabilities, such as cryptographic modules, RF modules [2](#)

peripheral

A hardware component or subsystem within the chip to interface with the outside world [2](#)

in-package flash

Flash integrated directly into the chip's package, and external to the chip die [14](#), [40](#)

off-package flash

Flash external to the chip's package [21](#), [40](#)

SPI boot mode

A boot mode in which users load and execute the existing code from SPI flash [34](#)

joint download boot mode

A boot mode in which users can download code into flash via the UART or other interfaces (see [Table 3-3](#) *Chip Boot Mode Control* > Note), and load and execute the downloaded code from the flash or SRAM [34](#)

eFuse

A one-time programmable (OTP) memory which stores system and user parameters, such as MAC address, chip revision number, flash encryption key, etc. Value 0 indicates the default state, and value 1 indicates the eFuse has been programmed [40](#)

Related Documentation and Resources

Related Documentation

- [ESP32-C5 Hardware Design Guidelines](#) – Guidelines on how to integrate the ESP32-C5 into your hardware product.
- [ESP32-C5 Series SoC Errata](#) – Descriptions of known errors in ESP32-C5 series of SoCs.
- [ESP32-C5 Technical Reference Manual](#) – Detailed information on how to use the ESP32-C5 memory and peripherals.
- *Technical Reference Manual LaTeX sources* – Public repository containing the LaTeX sources for Espressif chip TRMs.
<https://github.com/espressif/esp-technical-reference-manual-latex>
- *Certificates*
<https://espressif.com/en/support/documents/certificates>
- *ESP32-C5 Product/Process Change Notifications (PCN)*
<https://espressif.com/en/support/documents/pcns?keys=ESP32-C5>
- *ESP32-C5 Advisories* – Information on security, bugs, compatibility, component reliability.
<https://espressif.com/en/support/documents/advisories?keys=ESP32-C5>
- *Documentation Updates and Update Notification Subscription*
<https://espressif.com/en/support/download/documents>

Developer Zone

- [ESP-IDF Programming Guide for ESP32-C5](#) – Extensive documentation for the ESP-IDF development framework.
- *ESP-IDF* and other development frameworks on GitHub.
<https://github.com/espressif>
- *ESP32 BBS Forum* – Engineer-to-Engineer (E2E) Community for Espressif products where you can post questions, share knowledge, explore ideas, and help solve problems with fellow engineers.
<https://esp32.com/>
- *ESP-FAQ* – A summary document of frequently asked questions released by Espressif.
<https://espressif.com/projects/esp-faq/en/latest/index.html>
- *The ESP Journal* – Best Practices, Articles, and Notes from Espressif folks.
<https://blog.espressif.com/>
- See the tabs *SDKs and Demos*, *Apps*, *Tools*, *AT Firmware*.
<https://espressif.com/en/support/download/sdks-demos>

Products

- *ESP32-C5 Series SoCs* – Browse through all ESP32-C5 SoCs.
<https://espressif.com/en/products/socs?id=ESP32-C5>
- *ESP32-C5 Series Modules* – Browse through all ESP32-C5-based modules.
<https://espressif.com/en/products/modules?id=ESP32-C5>
- *ESP32-C5 Series DevKits* – Browse through all ESP32-C5-based devkits.
<https://espressif.com/en/products/devkits?id=ESP32-C5>
- *ESP Product Selector* – Find an Espressif hardware product suitable for your needs by comparing or applying filters.
<https://products.espressif.com/#/product-selector?language=en>

Contact Us

- See the tabs *Sales Questions*, *Technical Enquiries*, *Circuit Schematic & PCB Design Review*, *Get Samples (Online stores)*, *Become Our Supplier*, *Comments & Suggestions*.
<https://espressif.com/en/contact-us/sales-questions>

Revision History

Date	Version	Release notes
2026-06-25	v1.3	<ul style="list-style-type: none"> Updated IO MUX to HP IO MUX throughout the document, to differentiate from LP IO MUX Renamed the module from Elliptic Curve Digital Signature Algorithm (ECDSA) to ECDSA Digital Signature Peripheral (ECDSA_DS) throughout the document Renamed the module from Digital Signature Algorithm (DSA) to RSA Digital Signature Peripheral (RSA_DS) throughout the document Added Sections 2.3.5 Peripheral Pin Assignment, 5.7 Memory Specifications, and Glossary
2026-05-08	v1.2	<ul style="list-style-type: none"> Added ESP32-C5HR2 related information throughout the document Updated the feature list in Section 4.2.1.6 CAN FD Controller
2026-03-04	v1.1	<p>According to PCN20251201,</p> <ul style="list-style-type: none"> Added Figure 2-2 ESP32-C5HF4 Pin Layout (Top View), and updated ESP32-C5HF4 pin related information throughout the document Added Section 4.1.4.10 Key Manager, and updated key manager related information throughout the document
2025-11-05	v1.0	<ul style="list-style-type: none"> Removed content related to crystal frequency selection throughout the document In Chapter Features, added descriptions for the RF module Added Section 5.8 Reliability
2025-09-10	v0.6	In Chapter 1.2 Comparison , updated the ordering code ESP32-C5NR4 and ESP32-C5NF4 to ESP32-C5HR4 and ESP32-C5HF4
2025-05-19	v0.5	Preliminary release



Disclaimer and Copyright Notice

Information in this document, including URL references, is subject to change without notice.

ALL THIRD PARTY'S INFORMATION IN THIS DOCUMENT IS PROVIDED AS IS WITH NO WARRANTIES TO ITS AUTHENTICITY AND ACCURACY.

NO WARRANTY IS PROVIDED TO THIS DOCUMENT FOR ITS MERCHANTABILITY, NON-INFRINGEMENT, FITNESS FOR ANY PARTICULAR PURPOSE, NOR DOES ANY WARRANTY OTHERWISE ARISING OUT OF ANY PROPOSAL, SPECIFICATION OR SAMPLE.

All liability, including liability for infringement of any proprietary rights, relating to use of information in this document is disclaimed. No licenses express or implied, by estoppel or otherwise, to any intellectual property rights are granted herein.

The Wi-Fi Alliance Member logo is a trademark of the Wi-Fi Alliance. The Bluetooth logo is a registered trademark of Bluetooth SIG.

All trade names, trademarks and registered trademarks mentioned in this document are property of their respective owners, and are hereby acknowledged.

Copyright © 2026 Espressif Systems (Shanghai) Co., Ltd. All rights reserved.

www.espressif.com